



VC120 Video Conferencing System User Guide

Copyright

Copyright © 2017 YEALINK(XIAMEN) TECHNOLOGY CO., LTD.

Copyright © 2017 Yealink(Xiamen) Technology CO., LTD. All rights reserved. No parts of this publication may be reproduced or transmitted in any form or by any means, electronic or mechanical, photocopying, recording, or otherwise, for any purpose, without the express written permission of Yealink(Xiamen) Technology CO., LTD. Under the law, reproducing includes translating into another language or format.

When this publication is made available via the media, Yealink(Xiamen) Technology CO., LTD. gives its consent to downloading and printing copies of the content provided in this file for private use only and not for redistribution. No parts of this publication may be subject to alteration, modification or commercial use. Yealink(Xiamen) Technology CO., LTD. will not be liable for any damages arising from use of an illegally modified or altered publication.

Warranty

THE SPECIFICATIONS AND INFORMATION REGARDING THE PRODUCTS IN THIS GUIDE ARE SUBJECT TO CHANGE WITHOUT NOTICE. ALL STATEMENTS, INFORMATION, AND RECOMMENDATIONS IN THIS GUIDE ARE BELIEVED TO BE ACCURATE AND PRESENTED WITHOUT WARRANTY OF ANY KIND, EXPRESS OR IMPLIED. USERS MUST TAKE FULL RESPONSIBILITY FOR THEIR USE OF PRODUCTS.

YEALINK(XIAMEN) TECHNOLOGY CO., LTD. MAKES NO WARRANTY OF ANY KIND WITH REGARD TO THIS GUIDE, INCLUDING, BUT NOT LIMITED TO, THE IMPLIED WARRANTIES OF MERCHANTABILITY AND FITNESS FOR A PARTICULAR PURPOSE. Yealink(Xiamen) Technology CO., LTD. shall not be liable for errors contained herein nor for incidental or consequential damages in connection with the furnishing, performance, or use of this guide.

Declaration of Conformity



Hereby, Yealink(Xiamen) Network Technology CO., LTD. declares that this phone is in conformity with the essential requirements and other relevant provisions of the CE, FCC.

You can find the CE and FCC information from the label on the back of the VC120 Codec.

Statements of compliance can be obtained by contacting support@yealink.com.

CE Mark Warning

This device is marked with the CE mark in compliance with EC Directives 2014/30/EU and 2014/35/EU.

Part 15 FCC Rules

Any Changes or modifications not expressly approved by the party responsible for compliance could void the user's authority to operate the equipment.

This device is compliant with Part 15 of the FCC Rules. Operation is subject to the following two conditions:

1. This device may not cause harmful interference, and
2. This device must accept any interference received, including interference that may cause undesired operation.

Industry Canada (IC)

This Class [B] digital apparatus complies with Canadian ICES-003 Rules.

Class B Digital Device or Peripheral

Note: This device is tested and complies with the limits for a Class B digital device, pursuant to Part 15 of the FCC Rules. These limits are designed to provide reasonable protection against harmful interference in a residential installation. This equipment generates, uses, and can radiate radio frequency energy and, if not installed and used in accordance with the instructions, may cause harmful interference to radio communications. However, there is no guarantee that interference will not occur in a particular installation. If this equipment does cause harmful interference to radio or television reception, which can be determined by turning the equipment off and on, the user is encouraged to try to correct the interference by one or more of the following measures:

1. Reorient or relocate the receiving antenna.
2. Increase the separation between the equipment and receiver.
3. Connect the equipment into an outlet on a circuit different from that to which the receiver is connected.
4. Consult the dealer or an experienced radio/TV technician for help.

WEEE Warning



To avoid potential effects on the environment and human health as a result of the presence of hazardous substances in electrical and electronic equipment, end users of electrical and electronic equipment should understand the meaning of the crossed-out wheeled bin symbol. WEEE must not be regarded as unsorted municipal waste and must be collected and disposed of separately by a competent authority.

Customer Feedback

We are striving to improve our documentation quality and we appreciate your feedback. Email your opinions and comments to DocsFeedback@yealink.com.

GNU GPL INFORMATION

Yealink VC120 video conferencing system firmware contains third-party software under the GNU General Public License (GPL). Yealink uses software under the specific terms of the GPL. Please refer to the GPL for the exact terms and conditions of the license.

The original GPL license, source code of components licensed under GPL and used in Yealink products can be downloaded online:

<http://www.yealink.com/GPLOpenSource.aspx?BaseInfoCateId=293&NewsCateId=293&CateId=293>.

About This Guide

Thank you for choosing the Yealink VC120 full HD video conferencing system. It supports 1080P-full HD video conferencing and includes outstanding features such as good compatibility, easy deployment and intelligent network adaptability. This makes it the best choice for SME.

The Yealink VC120 full-HD video conferencing system is designed to help enterprises organize video conferences easily and efficiently. Users can expect to enjoy the high-quality video conferencing experience very cost-effectively.

This guide provides everything you need to start using your new video conferencing system quickly. First, verify with your system administrator that the IP network is ready for system configuration. Also be sure to read the **Overview** and **Getting Started** sections in this guide before you set up and use the VC120 video conferencing system.

In This Guide

Topics provided in this guide include:

- Chapter 1 [Overview](#)
- Chapter 2 [Getting Started](#)
- Chapter 3 [Customizing the VC120 Video Conferencing System](#)
- Chapter 4 [Using the VC120 Video Conferencing System](#)
- Chapter 5 [Using Cloud Platform](#)
- Chapter 6 [Using VCP41 with the PC or Mobile Device](#)
- Chapter 7 [Using the VCM30 Video Conferencing Microphone Array](#)
- Chapter 8 [Troubleshooting](#)

Summary of Changes

This section describes the changes to this guide for each release and guide version.

Changes for Release 22, Guide Version 22.15

The following section is new for this version:

- [Account Polling](#) on page 93
- [Using the StarLeaf Cloud Platform](#) on page 136
- [Controlling Dual Cameras](#) on page 123

Major update has occurred to the following section:

- [Changing the Video Input Source](#) on page 123

Changes for Release 22, Guide Version 22.5

The following sections are new for this version:

- [Remote Control via Web User Interface](#) on page 35
- [Meeting Blacklist](#) on page 69
- [USB Configuration](#) on page 70
- [Using Cloud Platform](#) on page 135

Major updates have occurred to the following sections:

- [Icon Instructions](#) on page 29
- [Setup Wizard](#) on page 42
- [Registration](#) on page 46
- [Idle Screen Display](#) on page 47
- [Call History Management](#) on page 80
- [Configuring Camera Presets](#) on page 121
- [Video Recording](#) on page 124
- [Screenshot](#) on page 128
- [Camera Issues](#) on page 153

Changes for Release 21, Guide Version 21.20

The following sections are new for this version:

- [Keyboard Input Method](#) on page 50

Major updates have occurred to the following sections:

- [Icon Instructions](#) on page 29
- [Setup Wizard](#) on page 42
- [Directory](#) on page 71
- [Bandwidth Settings](#) on page 87
- [Placing a Call Using the Remote Control](#) on page 97

Changes for Release 21, Guide Version 21.15

The following sections are new for this version:

- [VCP41 Video Conferencing Phone](#) on page 24
- [Website Snapshot](#) on page 63
- [Hiding Icons in a Call](#) on page 70
- [Chairman-Mode Conference](#) on page 99
- [Auto Recording](#) on page 127
- [8-Way Conference License](#) on page 130
- [Using VCP41 with the PC or Mobile Device](#) on page 135

Major updates have occurred to the following sections:

- [Packaging Contents](#) on page 13
- [Icon Instructions](#) on page 29
- [Setup Wizard](#) on page 42
- [Installing the VC120 Video Conferencing System](#) on page 38
- [Placing Multiple Calls](#) on page 98

Changes for Release 20, Guide Version 20.6

The following sections are new for this version:

- [Remote Control Battery Safety Information](#) on page 41
- [Meeting Password](#) on page 66
- [Meeting Whitelist](#) on page 68
- [Dual Screen](#) on page 118
- [Using the VCM30 Video Conferencing Microphone Array](#) on page 147

Major updates have occurred to the following sections:

- [VCC18/VCC20 HD Camera](#) on page 19
- [VCR10 Remote Control](#) on page 27
- [Installing the VC120 Video Conferencing System](#) on page 38
- [Audio Settings](#) on page 89
- [Far-end Camera Control](#) on page 91
- [Controlling the Camera](#) on page 120
- [Call Mute](#) on page 112
- [Video Recording](#) on page 124

- [Screenshot on page 128](#)

Table of Contents

About This Guide.....	V
In This Guide.....	v
Summary of Changes.....	v
Changes for Release 22, Guide Version 22.15	v
Changes for Release 22, Guide Version 22.5	vi
Changes for Release 21, Guide Version 21.20	vi
Changes for Release 21, Guide Version 21.15	vii
Changes for Release 20, Guide Version 20.6	vii
Table of Contents.....	ix
Overview	13
Packaging Contents.....	13
VC120 Package.....	13
VCP40 Package.....	15
VCP41 Package.....	16
VCM30 Package.....	17
System Component Instructions.....	17
VC120 Codec	17
VCC18/VCC20 HD Camera	19
Video Conferencing Phone.....	22
CPE80 Expansion Microphone	24
VCM30 Video Conferencing Microphone Array	26
VCR10 Remote Control.....	27
Icon Instructions	29
Icons on Display Device.....	29
Icons on Video Conferencing Phone	31
LED Instructions	32
User Interfaces	33
Web User Interface	34
Remote Control	34
Documentations	35
Getting Started.....	37
System Installation.....	37
Installing the VC120 Video Conferencing System	38
Installing the Camera.....	39
Installing Batteries for the Remote Control	41
Powering the System On or Off.....	42
Setup Wizard	42
Registration	46
Idle Screen Display.....	47
Navigating Menus on the Display Device	49
Keyboard Input Method	50
Entering Data and Editing Fields.....	51
System Status	52
Customizing the VC120 Video Conferencing System	55

General Settings.....	55
Automatic Sleep Time	55
Backlight.....	56
Site Name.....	57
Language.....	58
Time & Date	60
Key Tone.....	62
Website Snapshot.....	63
Volume Settings	64
Meeting Password	66
Meeting Whitelist	68
Meeting Blacklist	69
Hiding Icons in a Call.....	70
USB Configuration	70
Directory	71
Adding Local Contacts.....	72
Placing Calls to Contacts	73
Editing Local Contacts	74
Deleting Local Contacts.....	75
Searching for Contacts	75
Search Source List in Dialing	76
Importing/Exporting Contact Lists.....	78
Call History Management	80
Viewing Call History.....	81
Placing a Call from the Call History List	82
Deleting an Entry from the Call History List.....	83
Adding a Local Contact from the Call History List	85
Call Protocol	86
Bandwidth Settings.....	87
Audio Settings	89
Audio Output Device.....	89
Audio Input Device.....	90
Far-end Camera Control	91
Using the VC120 Video Conferencing System	93
Account Polling.....	93
Placing Calls.....	95
Placing a Call Using the Remote Control.....	97
Placing a Call Using the Video Conferencing Phone	97
Placing a Call via Web User Interface	98
Placing Multiple Calls	98
Chairman-Mode Conference	99
Answering or Rejecting Calls	107
Auto Answer	108
Do Not Disturb (DND)	109
Ending Calls	111
Call Management.....	112
Call Mute	112
Call Statistics.....	113
Presentation	114
Changing the Video Layout	116
Dual Screen	118
Controlling the Camera	120
Changing the Video Input Source	123

Video Recording	124
Screenshot	128
8-Way Conference License	130
Using Cloud Platform.....	135
Using the Yealink Cloud Platform	135
Dialing Yealink Cloud Numbers	135
Using the StarLeaf Cloud Platform.....	136
Dialing StarLeaf Cloud Numbers	137
Joining the StarLeaf Meeting.....	137
Using the Zoom Cloud Platform	138
Joining the Zoom Meeting	138
Using the BlueJeans Cloud Platform	139
Joining the BlueJeans Meeting	139
Using the Pexip Platform	140
Dialing Pexip Alias	140
Joining the Pexip Meeting	141
Using the Mind Platform.....	142
Joining the Mind Meeting	142
Using the Custom Platform.....	143
Using VCP41 with the PC or Mobile Device	145
Connecting a PC or Mobile Device to the VCP41	145
Adjusting the Volume of the PC or Mobile Audio	146
Removing the PC or Mobile Audio	146
Using the VCM30 Video Conferencing Microphone Array ...	147
Placing the VCM30	147
Muting or Unmuting the VCM30	147
Viewing VCM30 Information.....	148
Troubleshooting.....	151
System Diagnostics.....	151
General Issues	152
Camera Issues	153
Display Issues.....	154
Video & Audio Issues	155
System Maintenance.....	156
Regulatory Notices.....	165
Service Agreements	165
Limitations of Liability	165
Safety Instructions	165
Restriction of Hazardous Substances.....	167
Appendix A - Time Zones.....	169
Index	173

Overview

This chapter provides an overview of the VC120 video conferencing system. Topics include:

- [Packaging Contents](#)
- [System Component Instructions](#)
- [Icon Instructions](#)
- [LED Instructions](#)
- [User Interfaces](#)
- [Documentations](#)

If you require additional information or assistance with your new system, contact your system administrator.

Packaging Contents

The VC120 video conferencing system can work with the VCP40 video conferencing phone, VCP41 video conferencing phone or VCM30 video conferencing microphone array. You can purchase any combination according to your needs:

Note

We recommend that you use the accessories provided or approved by Yealink. The use of unapproved third-party accessories may result in reduced performance.

VC120 Package

- **VC120 Codec**



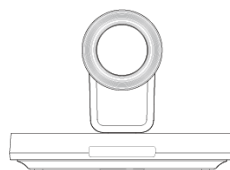

- **HD Camera**

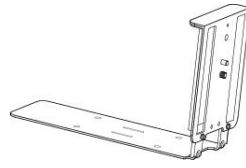

- **L-Bracket** (for installing the camera)



- **Camera Mounting Accessories**

- Expansion bolts  × 4
- Screws(Specificaiton: T4×30)  × 4
- Screws(Specificaiton: M3×8)  × 2

- **VCR10 Remote Control**



- **AAA Batteries×2**



- **Power Adapter**

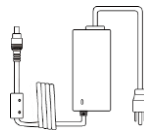

- **Cables**

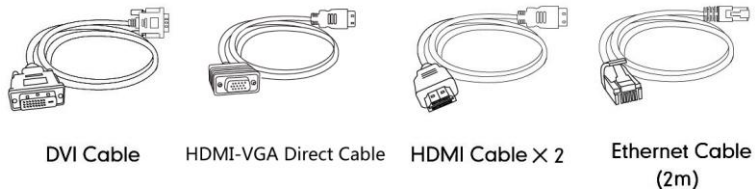

- **Velcro×2**



- **Cable Ties×5**

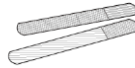

- **Quick Start Guide**

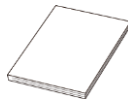

VCP40 Package

- **VCP40 Video Conferencing Phone**

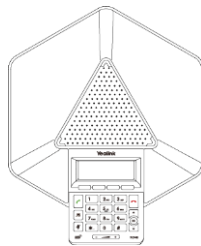

- **Ethernet Cable (7.5m)**

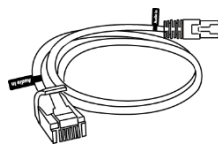

Locate the Audio In port on the VC120 Codec, and connect it to the Audio Out port of the VCP40 video conferencing phone with the 7.5m Ethernet cable. VCP40 video conferencing phone can work as an audio device for the VC120 video conferencing system. You can also place calls, answer calls or view directory and history on the VCP40 video conferencing phone.

VCP41 Package

- **VCP41 Video Conferencing Phone**

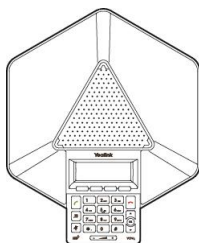

- **Expansion Microphone CPE80×2**

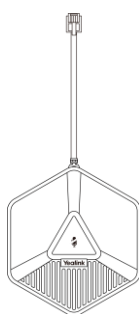

- **Ethernet Cable (7.5m)**

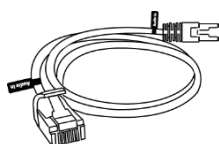

- **3.5mm Audio Cable** (for connecting a PC/Mobile device to the VCP41)



Locate the Audio In port on the VC120 Codec, and connect it to the Audio Out port of the VCP41 video conferencing phone with the 7.5m Ethernet cable. VCP41 Video conferencing phone can work as an audio device for the VC120 video conferencing system. You can also place calls, answer calls or view directory and history on the VCP41 video conferencing phone.

VCM30 Package

- **VCM30 Video Conferencing Microphone Array**

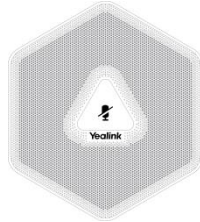

- **Ethernet Cable (7.5m)**

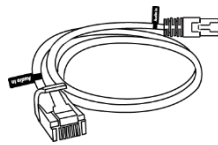

Locate the Audio In port of on the 120 Codec, and connect it to the Audio Out port of the VCM30 with the 7.5m Ethernet cable. VCM30 video conferencing microphone array can work as the audio input device for the VC120 video conferencing system. For more information, refer to [Audio Input Device](#) on page 90.

Note Check the list before installation. If you find anything missing, contact your system administrator.

System Component Instructions

Before installing and using the VC120 video conferencing system, you need to be familiar with the following system components:

- [VC120 Codec](#)
- [VCC18/VCC20 HD Camera](#)
- [Video Conferencing Phone](#)
- [CPE80 Expansion Microphone](#)
- [VCM30 Video Conferencing Microphone Array](#)
- [VCR10 Remote Control](#)

VC120 Codec

VC120 codec compresses outgoing video and audio data, transmits this information to the far end, and decompresses incoming data. It supports 16:9 and 4:3 aspect ratios. It can be compatible with different audio output devices, and can adapt to the display devices

automatically.

You do not need to change the VC120 codec once it has been installed properly in your environment.

VC120 codec front panel

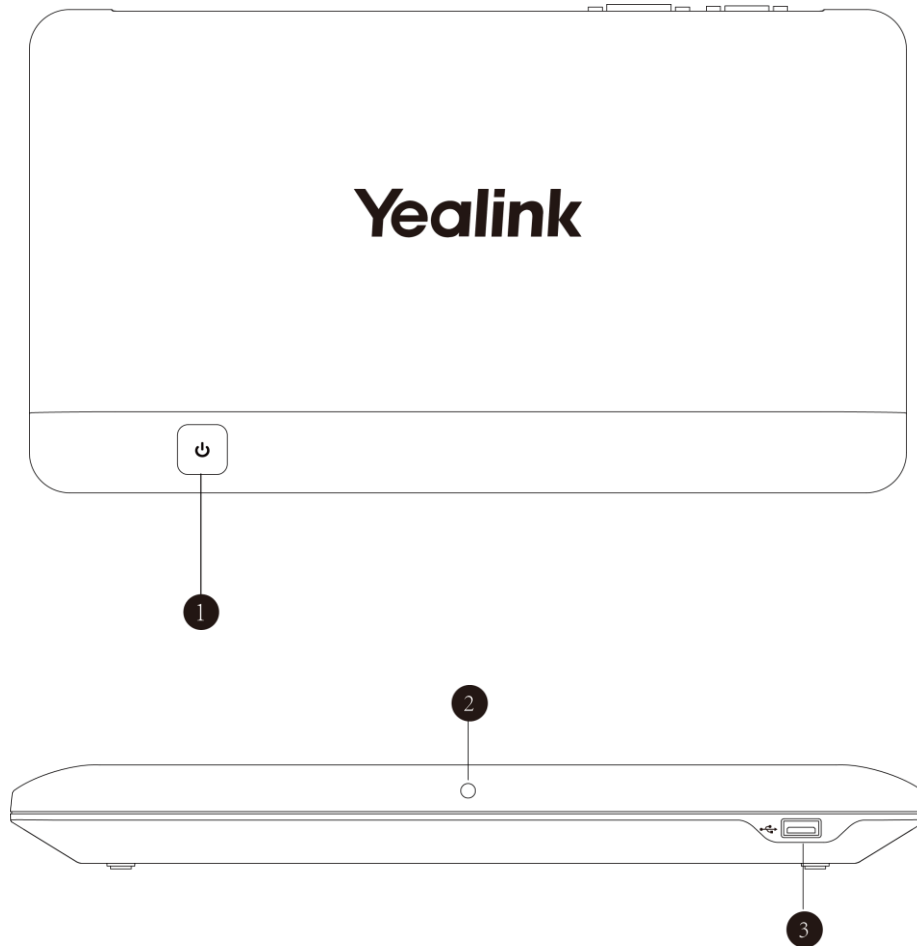

VC120 codec back panel

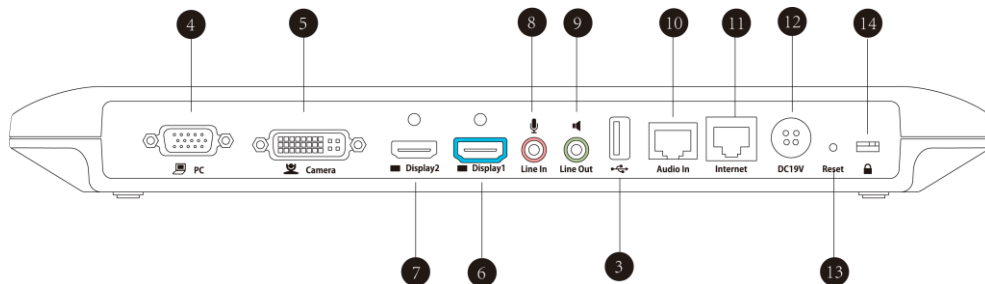

	Port Name	Description
①	Power Button	Powers the system on or off.
②	LED Indicator	Indicates different system statuses. For more information, refer to LED Instructions on page 32.

	Port Name	Description
③	USB	Inserts a USB flash drive to one of the two USB port for storing screenshots, recording videos or capturing packets. Note: If two USB flash drives are connected, only the latter one can be identified.
④	PC	Connects to a PC for sharing documents or videos during a call.
⑤	Camera	Connects to a camera.
⑥	Display1	Connects to a display device for displaying video images. When connecting to only one display device, Display1 port on the VC120 codec is the only available port.
⑦	Display2	Connects to secondary display device for displaying video images.
⑧	Line In	Connects to an audio input device using an audio cable (3.5mm).
⑨	Line Out	Connects to an audio output device using an audio cable (3.5mm).
⑩	Audio In	Connects to the video conferencing phone or the VCM30 video conferencing microphone array.
⑪	Internet	Connects to the network device.
⑫	DC19V	Connects to the power source via a power adapter.
⑬	Reset Key	Resets the system to factory defaults.
⑭	Security Slot	Allows you to connect a universal security cable to VC120 codec, so you can lock it down. The system cannot be removed when locked.

VCC18/VCC20 HD Camera

The VCC18 HD camera supports 18x optical zoom, white balance and automatic gain. The VCC20 HD camera supports 12x optical zoom, white balance and automatic gain. You can place the camera on the table or mount it on a wall.

The following takes VCC20 HD camera as an example to introduce camera performance.

The front of the HD camera

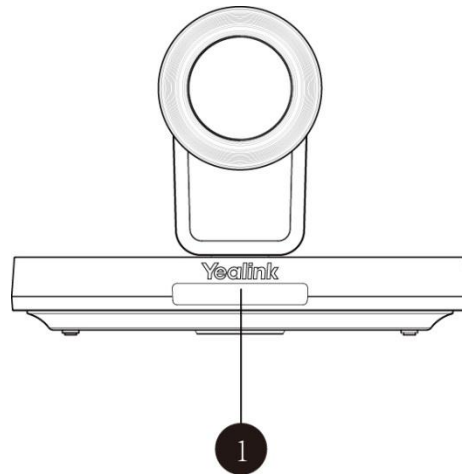

	Port Name	Description
①	LED Indicator	Indicates different system statuses. For more information, refer to LED Instructions on page 32.

The back of the HD camera

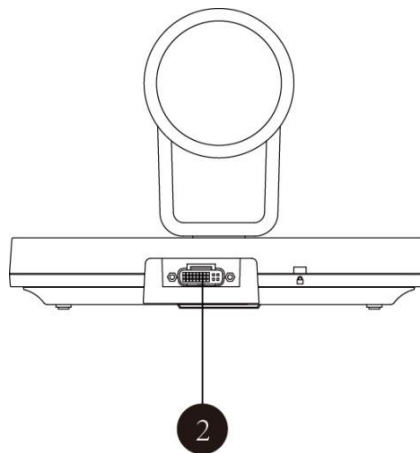

	Port Name	Description
②	Camera	Connects to the Camera port on the VC120 codec using a DVI cable.

You can use the remote control to adjust the position or focus of the camera. The camera can be panned (± 100 degrees range), tilted (± 30 degrees range).

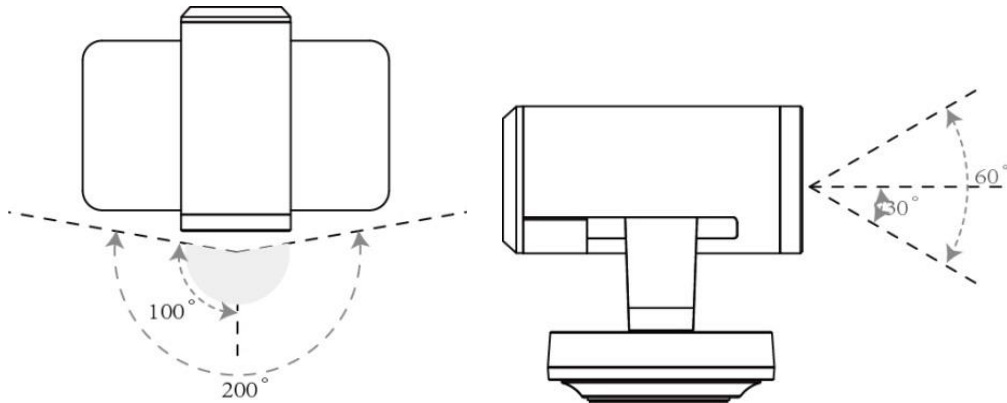

Infrared Sensor

The infrared sensor is located within the Yealink logo. Aim the remote control at the camera IR sensor to operate the unit.

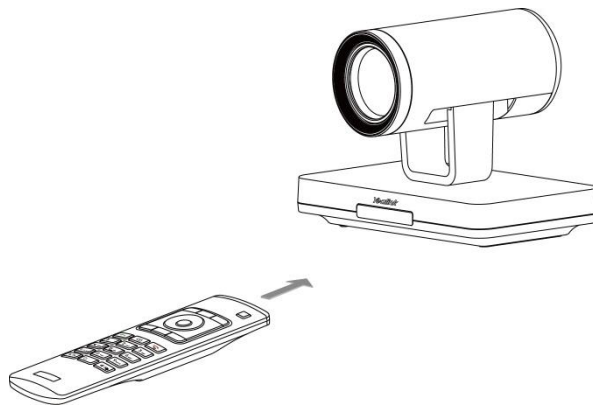

Note

Avoid physically turn camera while system is powered on to prevent permanent damaging the camera. Always use the remote control to pan and tilt the camera head.

Video Conferencing Phone



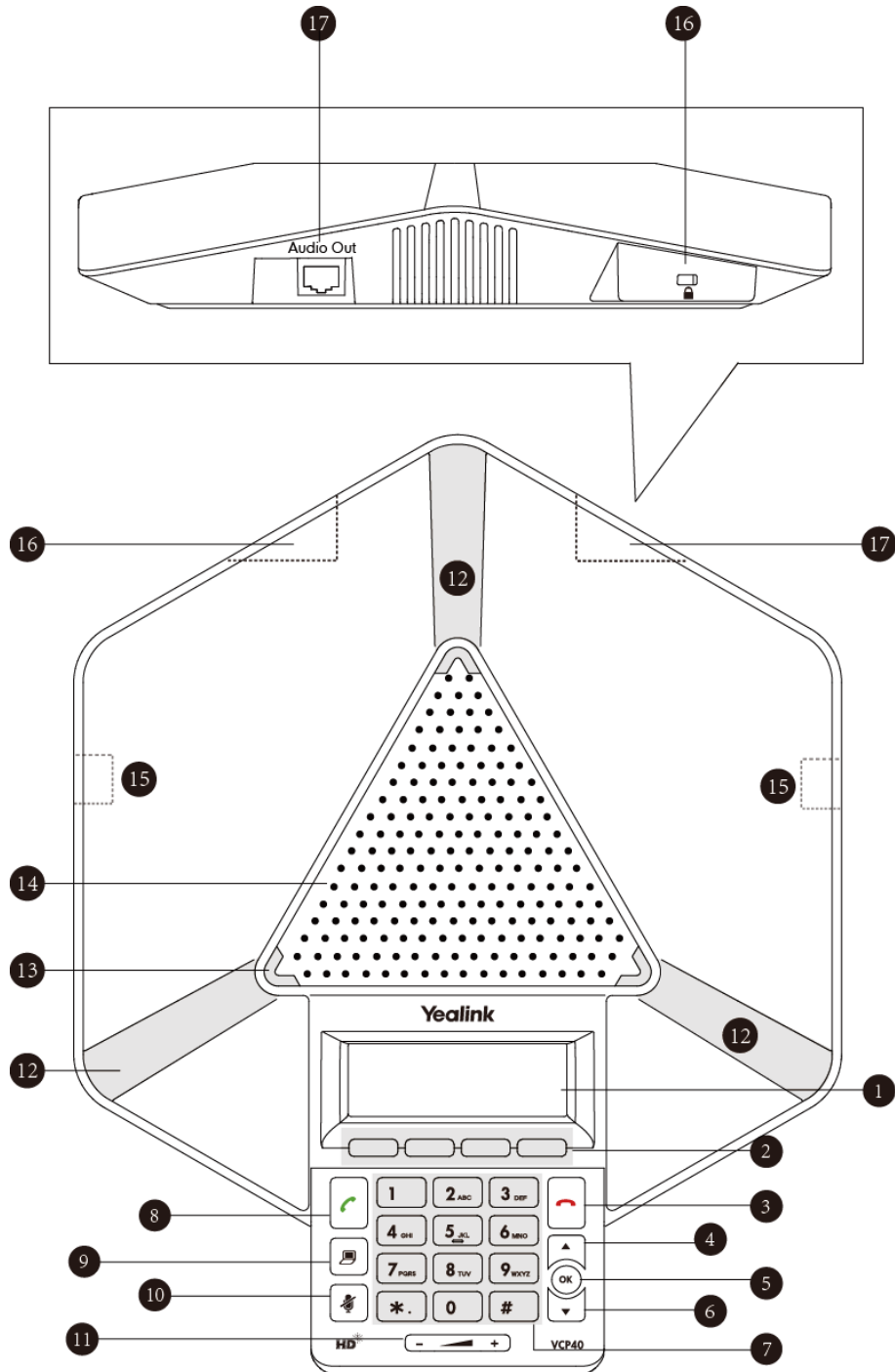

VCP40 Video Conferencing Phone

The VCP40 video conferencing phone supports 360-degree audio pickup to achieve ultra-HD voice.

Connect the VCP40 phone to the VC120 codec. It can work as an audio device for the system. You can also place calls, answer calls or view directory and history on the VCP40 phone.



System component instructions of the VCP40 phone are:

	Item	Description
①	LCD Screen	Shows information about calls, messages, soft keys, time, date and other relevant data: <ul style="list-style-type: none"> • Call information—call duration • Icons (for example, ) • Missed call information • Time and date
②	Soft Keys	Label automatically to identify their context-sensitive features.
③	On-hook Key	Rejects or ends a call or returns to the previous screen.
④		Scrolls upwards through the displayed information.
⑤		Enters list or answers incoming calls.
⑥		Scrolls downwards through the displayed information.
⑦	Keypad	Generates the digits and special characters ". " "*" "#".
⑧	Off-hook Key	Initiates a call or answers a call.
⑨	Presentation Key	Enables or disables presentation.
⑩	Mute Key	Toggles the mute feature.
⑪	Volume Key	Adjusts the volume of the speakerphone and ringer.
⑫	Microphone	Picks up voice.
⑬	LED Indicators	Indicate phone and call statuses.
⑭	Speakerphone	Provides ringer and hands-free (speakerphone) audio output.
⑮	MIC Port	Connects a CPE80 expansion microphone to one of two MIC ports.
⑯	Security Slot	Allows you to connect a universal security cable to lock down your phone. The phone cannot be removed when locked.
⑰	Audio Out Port	Connects to the video conferencing phone using the 7.5m Ethernet cable labeled Audio in. Provides the power supply for the video conferencing phone.

VCP41 Video Conferencing Phone

The features of VCP41 video conference phone are similar to VCP40. For more information, refer to [VCP40 Video Conferencing Phone](#) on page 22. The only difference is that the back of VCP41 has a PC/Mobile port, which allows you to connect to an optional PC or Mobile Device, so that you can listen to the PC or mobile audio using your VCP41 video conferencing phone.

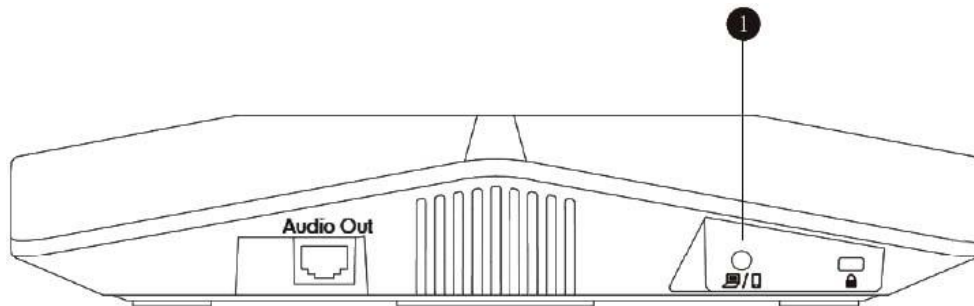

	Item	Description
①	PC/Mobile Port	Allows you to connect an optional PC or Mobile Device to your phone so that you can listen to the PC or mobile audio using your VCP41 video conferencing phone.

For more information on how to use VCP41 with the PC or mobile device, refer to [Using VCP41 with the PC or Mobile Device](#) on page 135.

CPE80 Expansion Microphone

If your video conferencing room is large, you can add extra CPE80 expansion microphones to the MIC ports on the video conferencing phone to expand the audio range.

Video conferencing phone has two MIC ports. Up to two expansion microphones can be connected to a video conferencing phone. CPE80 is a directional microphone. Its coverage range is a 120 degree. Always ensure that the speaker faces the expansion microphone.

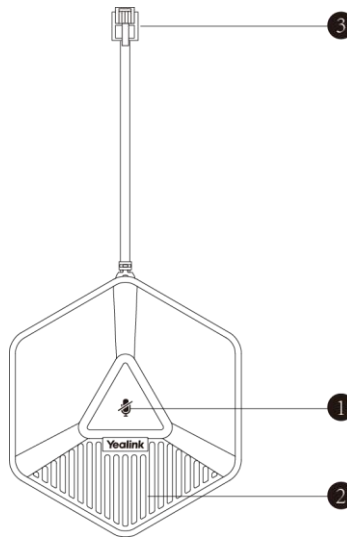

	Item	Description
①	Mute Indicator LED	Toggles and indicates mute feature.
②	Microphone	Transmits sound to other phones.
③	MIC Connector	Allows you to connect to the MIC port on the video conferencing phone.

VCM30 Video Conferencing Microphone Array

The VCM30 is a video conferencing microphone array which can work as the audio input device for VC120 video conferencing system. It has 3 built-in microphones which support 360-degree audio pickup at a radius of up to 3 meters. There is a mute button on its top. You can mute or unmute the VCM30 by tapping the mute button during a call.

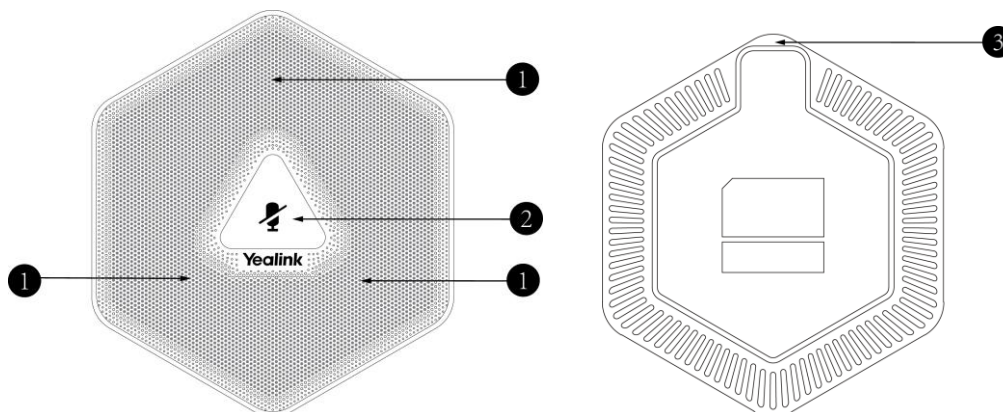

	Name	Description
①	Built-in Microphones	Support 360-degree audio pickup at a radius of up to 3 meters.
②	Mute Button	Mutes or unmutes the VCM30. For more information on the mute indicator LED, refer to LED Instructions on page 32.
③	Audio Out Port	Connects to the Audio In port of VC120 codec using the 7.5m Ethernet cable labeled Audio In. Provides the power supply for the VCM30.

For more information on how to use VCM30 video conferencing microphone array, refer to [Using the VCM30 Video Conferencing Microphone Array](#) on page 147.

VCR10 Remote Control

The VCR10 remote control provides 3 shortcut keys. It can help users to organize conference easily with intuitive and efficient operation in all screens.

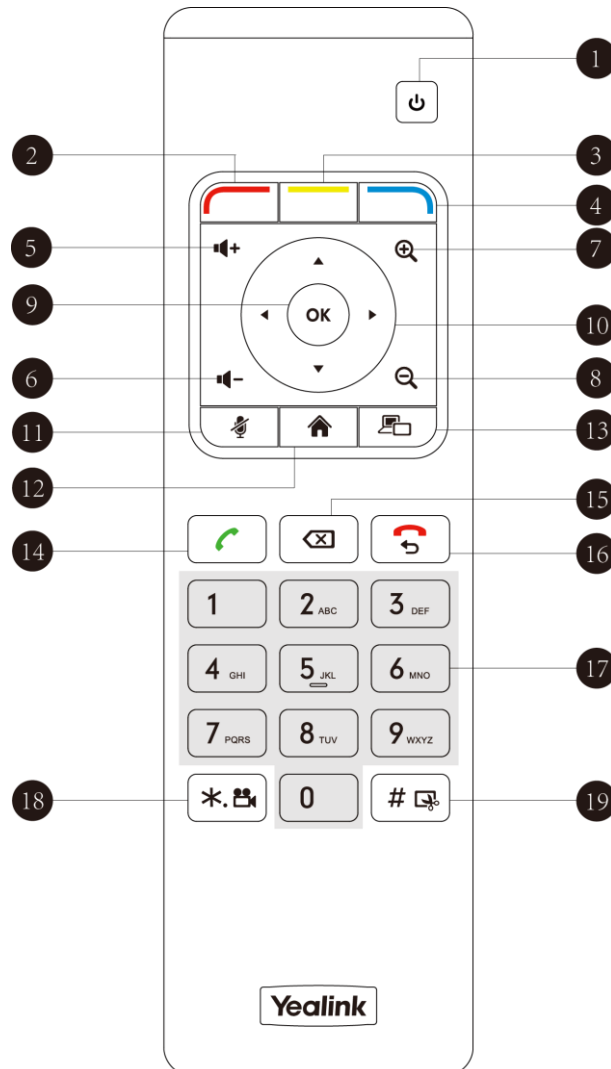

Hardware components of the remote control:

	Item	Description
①	Sleep Key	Puts the system to sleep or wakes the system up.
②	Red Shortcut Key	Located at the bottom left of the screen. Label automatically identifies context-sensitive features. In the idle screen, this is used to enter main menu screen, corresponds to the Menu soft key.
③	Yellow Shortcut Key	Located at the bottom center of the screen. Label automatically identifies context-sensitive features. In the idle screen, this is used to enter the pre-dialing screen, and corresponds to the Call soft key.









	Item	Description
④	Blue Shortcut Key	Located at the bottom right of the screen. Label identifies context-sensitive features. In the idle screen, this is used to save and check the camera preset position, and corresponds to the Preset soft key.
⑤	Vol+	Increases the system volume.
⑥	Vol-	Decreases the system volume.
⑦	Zoom out Key	<ul style="list-style-type: none"> Decreases the camera zoom or the captured image magnifications. Behaves as page down in a multiple page list.
⑧	Zoom in Key	<ul style="list-style-type: none"> Increases the camera zoom or the captured image magnifications. Behaves as page up in a multiple page list.
⑨	OK Key	Confirms actions or answers incoming calls.
⑩	Navigation Key	<ul style="list-style-type: none"> In the menu screen, press ◀ or ▶ to switch menus, press ▲ or ▼ to select items. In the idle screen, pan and tilt the camera to adjust the viewing angle.
⑪	Mute Key	Toggles the mute feature.
⑫	Home Key	<ul style="list-style-type: none"> Returns to the idle screen when in the menu screen. Enters the pre-dialing screen during a call.
⑬	Video Source Key	Switches the input source between Camera, Camera-PC, or PC.
⑭	Off-hook Key	<ul style="list-style-type: none"> Enters the pre-dialing screen. Places a call. Answers a call.
⑮	Delete key	<ul style="list-style-type: none"> Deletes one character at a time. Long press to delete all characters in the input field. On the idle screen or during a call, long press it for 2 seconds to start capturing packets and long press it for 2 seconds again to stop capturing packets.
⑯	On-hook Key	<ul style="list-style-type: none"> Ends a call or exits from a conference call. Returns to the previous screen when not in a call.





















	Item	Description
⑰	Keypad	<ul style="list-style-type: none"> Enters digits. Long press <input type="text" value="0"/> to generate a special character "@" in the input field. Enters the pre-dialing screen. Stores the preset position of the camera.
⑱	Video Recording Key	<ul style="list-style-type: none"> Generates a special characters ".". Starts/Stops recording video.
⑲	Snapshot Key	<ul style="list-style-type: none"> Generates a pound key (#). Captures the image from the camera.









Icon Instructions

Icons on Display Device

Icons appearing on the display device are described in the following table:











Icon	Description
	Network is disconnected
	Network is available
	Packet loss
	Video conferencing phone is not connected
	Camera is not connected
	SIP account is registered
	H.323 account is registered
	Log into the Yealink Cloud platform
	Log into the StarLeaf/Zoom/Pexip/BlueJeans/Mind platform











Icon	Description
	Lowercase letters input mode of the on-screen keyboard
	Uppercase letters input mode of the on-screen keyboard
	Characters input mode of the on-screen keyboard
	Auto answer
	Missed calls
	Volume is 0
	Do not disturb
	Do not disturb during a call
	Call mute
	Call encryption
	Call Hold
	Output volume is 0 during a call
	The content of the local camera
	Focus content
	Camera position
	Record a video
	Dialed calls (H.323 account/SIP account/IP Call)
	Dialed calls (Cloud platform)
	Received calls (H.323 account/SIP account/IP Call)
	Received calls (Cloud platform)
	Missed calls (H.323 account/SIP account/IP Call)

Icon	Description
	Missed calls (Cloud platform)
	PC/Mobile mode (when a PC or mobile device is connected to the VCP41)
	Dual screen mode
	Dual video sources (when a PC is connected to the PC port on the VC120 codec)
	A USB flash drive is inserted to the USB port on the VC120 codec
	Local contact
	Yealink Cloud contact
	VPN is enabled

Icons on Video Conferencing Phone

Icons appearing on the video conferencing phone are described in the following table:

Icon	Description
 (Flashing)	Network is unavailable
	SIP account is registered (the icon flashes when it is not registered successfully)
	H.323 account is registered (the icon flashes when it is not registered successfully)
	Log into the Yealink Cloud platform
	Log into the StarLeaf/Zoom/Pexip/BlueJeans/Mind platform
	Auto answer
	Do not disturb
	Call is muted
	Volume is 0
	A USB flash drive is inserted to the port on the VC120 codec

Icon	Description
	Record a video
	Local contact
	Yealink Cloud contact
	Conference call
	Dialed calls (H.323 account/SIP account/IP Call)
	Dialed calls (Cloud platform)
	Received calls (H.323 account/SIP account/IP Call)
	Received calls (Cloud platform)
	Missed calls (H.323 account/SIP account/IP Call)
	Missed calls (Cloud platform)
	PC/Mobile mode (when a PC or mobile device is connected to the VCP41)

LED Instructions

Indicator LED on the VC120 codec:

LED Status	Description
Solid green	The VC120 codec is powered on. The VC120 codec is upgrading firmware.
Solid red	The VC120 codec is in sleep mode.
Solid orange	System exception (e.g., network unavailable, update failure).
Off	The VC120 codec is powered off, or is not connect to the power adapter.

Indicator LED on the camera:

LED Status	Description
Solid green	The camera is properly connected to the VC120 codec, and the VC120 codec is powered on.
Solid red	The VC120 codec is in sleep mode.
Flashing green	Press the key on the remote control.
Off	The camera is not connected properly to the VC120 codec, or the VC120 codec is powered off.

Indicator LED on the video conferencing phone:

LED Status	Description
Solid red	The phone is initializing. The call is muted.
Flashing red	The phone is ringing.
Solid green	The phone is placing a call. There is an active call on the phone.
Off	The phone is idle.

Mute Indicator LED on the VCM30 video conferencing microphone array:

LED Status	Description
Solid red	The VCM30 is muted when the VC120 is during a call.
Flashing red	The VC120 is ringing.
Solid green	The VCM30 is connected to the VC120 codec within the first 5 seconds. The VC120 is placing a call. The VCM30 is unmuted when the VC120 is during a call.
Off	The VCM30 is not connected to the VC120 codec. The VCM30 is idle.

Indicator LED of the Internet port on the VC120 codec:

LED Status	Description
Indicator LED on the left is off	Network is not connected.
Indicator LED on the left is solid green	Network is connected.
Indicator LED on the right is flashing yellow	Sending and receiving data.

User Interfaces

There are two ways to customize the configurations of your VC120 video conferencing system:

- [Web User Interface](#)
- [Remote Control](#)



Note

The display device and remote control constitute the system user interface. This allows the user to execute all call operation tasks and basic configuration changes directly. Detailed operational steps will be explained in the feature section.

Web User Interface

You can customize your system via web user interface. To access the web user interface, you need to know the IP address of your new system.

To obtain the IP address, do one of the following:

- The IP address of the system is shown on the top right corner of the display device.
- Press  (**Menu** soft key) on your remote control and select **Status** -> **Network**.
The display device shows network information about the system.
- Press  on the video conferencing phone when the phone is idle and select **Network**.
The LCD screen of the phone displays the network information of the system.

Log into the web user interface:

1. Enter the IP address (e.g., <http://192.168.0.10> or 192.168.0.10) in the address bar of a web browser on your PC, and then press the **Enter** key.
2. Enter the administrator user name and password.

The default user name is "admin" (case-sensitive), and the default password is "0000".

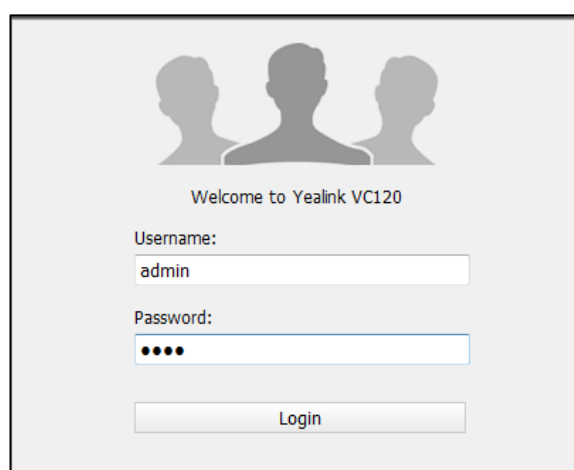

3. Click **Login**.

After you log into the web user interface successfully, you can click **Logout** on the top right corner of the web interface to log out.

Remote Control

You can use the remote control and display device to configure and use the VC120 video conferencing system.

For more information on the function of each key on the remote control, refer to [VCR10 Remote Control](#) on page 27.

The **Advanced** option is only accessible to the administrator. The default administrator password is "0000". For more information on how to view, enter and edit menu settings menu

on the display device, refer to [Navigating Menus on the Display Device](#) on page 49 and [Entering Data and Editing Fields](#) on page 51.

Remote Control via Web User Interface

In addition to using the remote control, you can also control the video conferencing system via web user interface.

To control video conferencing system via web user interface:

1. Click **Home**->**Remote Control** when the system is idle or during a call.

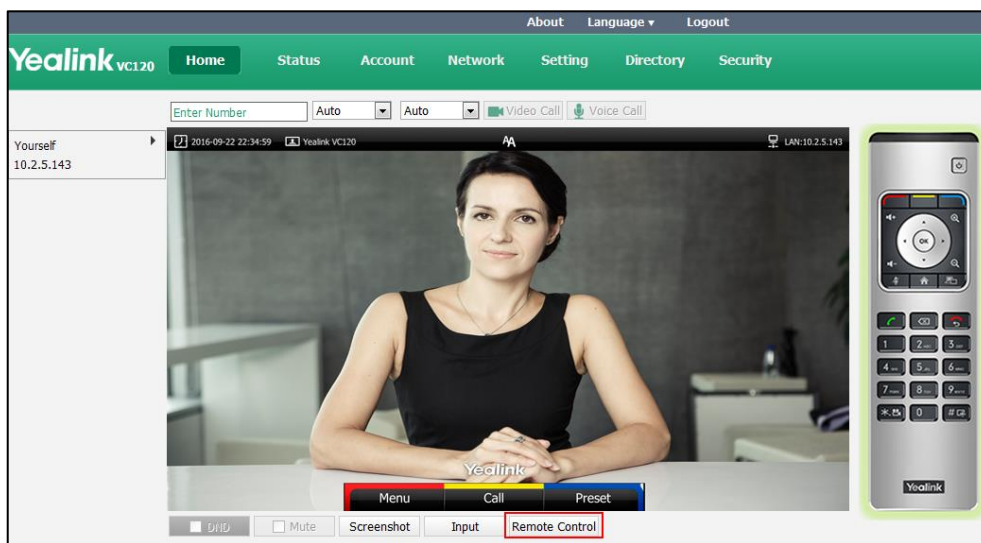

2. Click the keys on the virtual remote control to control the video conferencing system.
3. Click **Remote Control** to hide the virtual remote control.

Documentations

The following table shows documentations available for the VC120 video conferencing system.

Name	Contents	Where found	Language
Yealink VC120 Video conferencing System Quick Start Guide	System installation and network configuration	On the website/ In the package	English/Chinese
Yealink VC120 Video Conferencing System User Guide	System/Web user interface settings Customizing and using the system	On the website	English/Chinese

Name	Contents	Where found	Language
Yealink VC400 & VC120 Video Conference Room Deployment Solution	Conference room layout, environmental requirements and installation recommendations for the system	On the website	English/Chinese
Yealink VC Series Video Conferencing System Network Deployment Solution	Network deployment for the VCS under various scenarios	On the website	English/Chinese
Yealink VC400 & VC120 Video Conferencing System Administrator Guide	Functionality and configuration of the Yealink VCS	On the website	English/Chinese

Note

You can also download the latest documentations online:

<http://support.yealink.com/documentFront/forwardToDocumentFrontDisplayPage>.

Getting Started

This chapter provides the following basic installation instructions and information for achieving the best performance from your VC120 video conferencing system. Topics include:

- [System Installation](#)
- [Powering the System On or Off](#)
- [Setup Wizard](#)
- [Registration](#)
- [Idle Screen Display](#)
- [Navigating Menus on the Display Device](#)
- [Keyboard Input Method](#)
- [Entering Data and Editing Fields](#)
- [System Status](#)

If you require additional information, or assistance to help you use your new phone, contact your system administrator.

System Installation

This section introduces the following:

- Installing the VC120 video conferencing system
- Installing the camera
- Installing batteries for the remote control

Note

Up to two display devices can be connected to the VC120 codec. Because the display device is not included in the package, you need to purchase it separately if required. Ensure that the purchased display device supports HDMI input.

When connecting only one display device to the VC120 codec, Display1 port is the only available port. If dual screen mode is required, you can connect another display device to the Display2 port.

Because DVI cable is tailor-made, please use the Yealink-supplied DVI cable.

To prevent shock, do not connect the power adapter and turn on the power before connecting all system components.

Installing the VC120 Video Conferencing System

Do the following:

1. Connect the Internet port of the VC120 codec to a switch/hub device port with the supplied 2m Ethernet cable.
2. Locate the Camera port on the back of the VC120 codec, and connect it to the Camera port on the camera with the supplied DVI cable.
3. (Optional.) Locate the Audio In port of the VC120 codec, do one of the following:
 - Connect it to the Audio Out port on the video conferencing phone with the 7.5m Ethernet cable that labeled Audio In, and then connect the free end of the expansion microphone cables to MIC ports on the video conferencing phone.

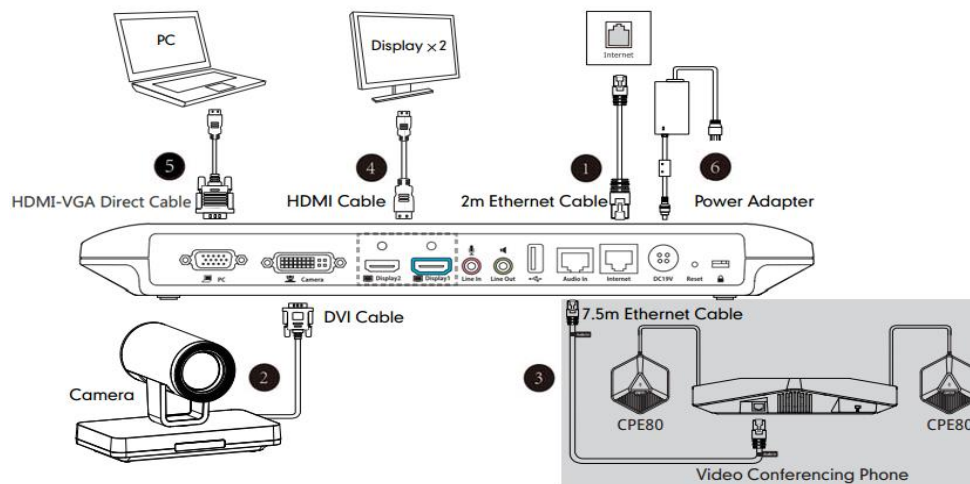

- Connect it to the Audio Out port on the VCM30 video conferencing microphone array with the 7.5m Ethernet cable that labeled Audio In.

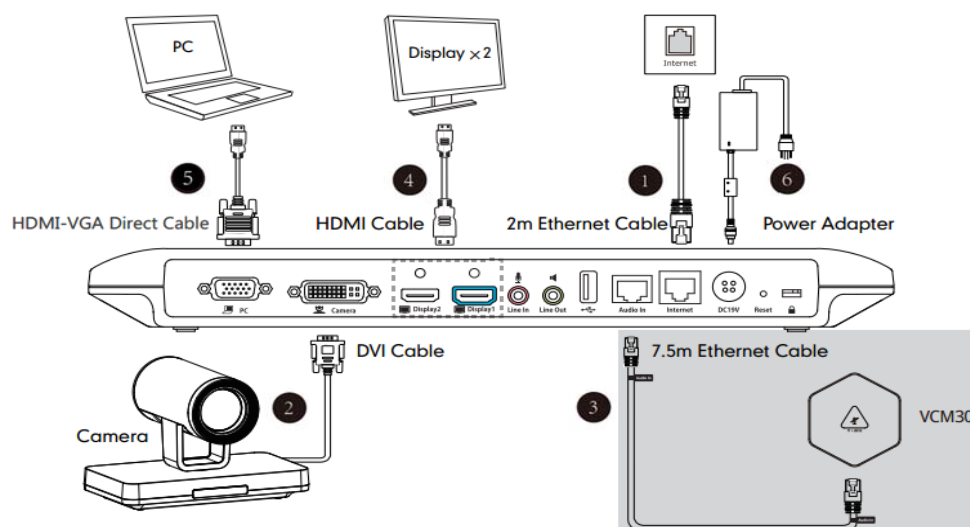

4. Locate the Display1 port on the VC120 codec, and connect it to the HDMI port on the

display device with the supplied HDMI cable (Make sure the display device is powered on)

5. (Optional.) Locate the PC port of the VC120 codec and connect it to the HDMI port on the PC with the supplied HDMI-VGA direct cable for sharing content.
6. Connect the DC19V port on the VC120 codec to an AC power outlet with the supplied power adapter and power cord.

Note

The VC120 video conferencing system should be used with Yealink original power adapter (19V/3.42A) only. The use of the third-party power adapter may cause the damage to the system.

You can fasten all cables with cable ties after all devices are connected.



Installing the Camera

You can choose to mount the camera on your TV or a wall, depending on your actual needs.

a) Mounting the camera on a TV

When the thickness of your TV is between 35-120 mm, you can mount the camera on your TV.

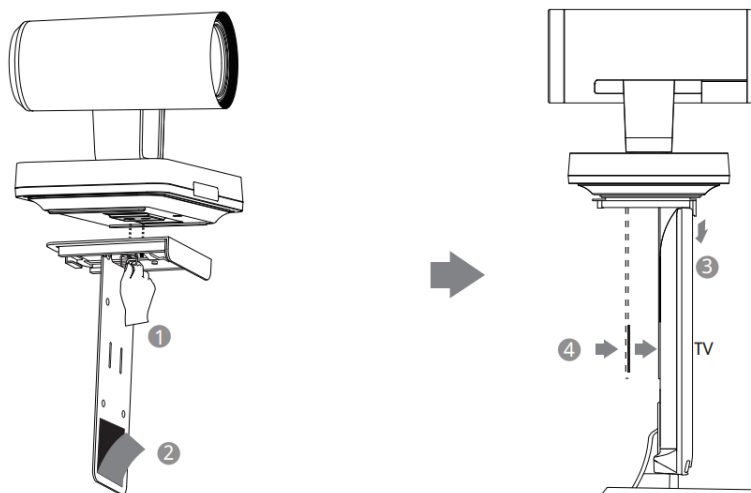

Do the following:

1. Lock the camera to the L-bracket.
2. Remove the protection of the Velcro.
3. Put the L-bracket on the top of the TV.
4. Make sure the back of the TV is clean, and then adjust the bracket to ensure close adhesion to the back of the TV with Velcro.

b) Mounting the camera on a wall

You can also decide to mount the camera on a wall. The recommended height for camera positioning is 1.5m-1.8m above the ground.

Do the following:

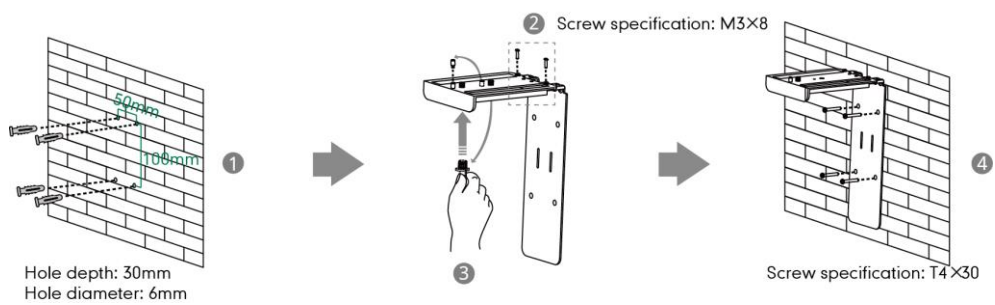

1. Punch holes into the wall and then insert the expansion bolts.
Installation location for the expansion bolts and punching requirement are shown above.
2. Lock the L-bracket with the M3×8 screws.
3. Move the setscrews on the L-bracket to the left holes.
4. Lock the L-bracket to the wall with T4×30 screws.
5. Connect one end of the DVI cable to the camera and put the other end of the cable through the L-bracket.

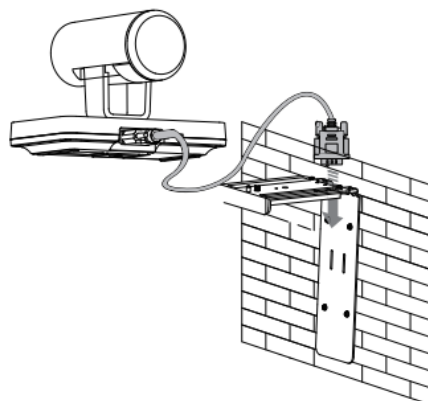

6. Lock the camera to the L-bracket, and then connect the other end of the DVI cable to the VC120 codec.

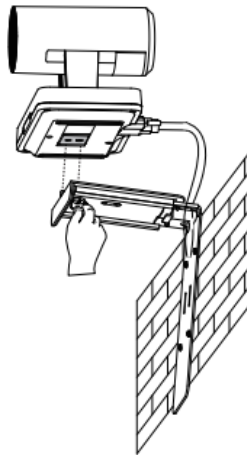

Installing Batteries for the Remote Control

Do the following:

1. Open the battery cover on the back of the remote control.
2. Insert the batteries with the correct polarity.
3. Replace the battery cover.

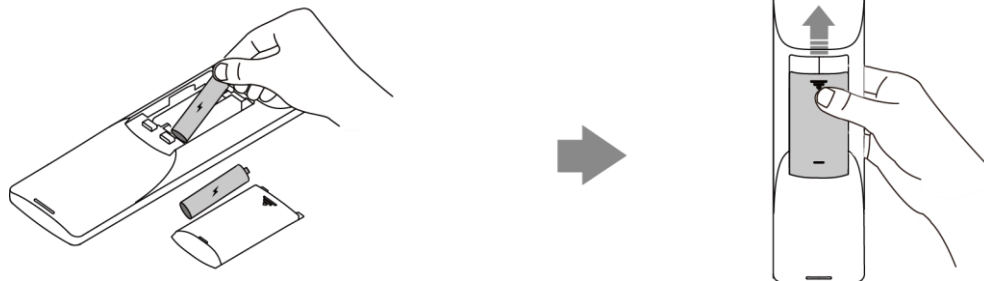

Remote Control Battery Safety Information

- Never make wrong polarity connection when charging and discharging battery packs.
- Avoid crushing, puncturing, or putting a high degree of pressure on any battery, as this can cause an internal short-circuit, resulting in overheating.
- Remove the batteries if they are not in use for long period of time. Battery leakage and corrosion can damage the remote control, dispose batteries safely.
- Do not dispose used batteries in domestic waste. Dispose batteries at special collection points or return to stores if applies.
- Do not dispose batteries in a fire.

Powering the System On or Off

Note



Caution! To avoid corrupting the system, you should always power off the system using the power button on the VC120 codec. After turning the power off in this way, wait at least 15 seconds before you unplug the system from its power source. This helps to ensure that the system powers off correctly.

To power on the system:

After all components are connected, press  on the VC120 codec. The indicator LED on the VC120 codec then illuminates solid green.

To power off the system:

Do one of the following:

- Long press  on the VC120 codec.
- Short press , the display device will prompt "Press the power button to turn off the system. Press any button on remote control to cancel".

Press  again to power off the system or press any button on the remote control to cancel.

Setup Wizard

When you first start up or reset the system, the display device will display the setup wizard.

To configure the setup wizard via the remote control:

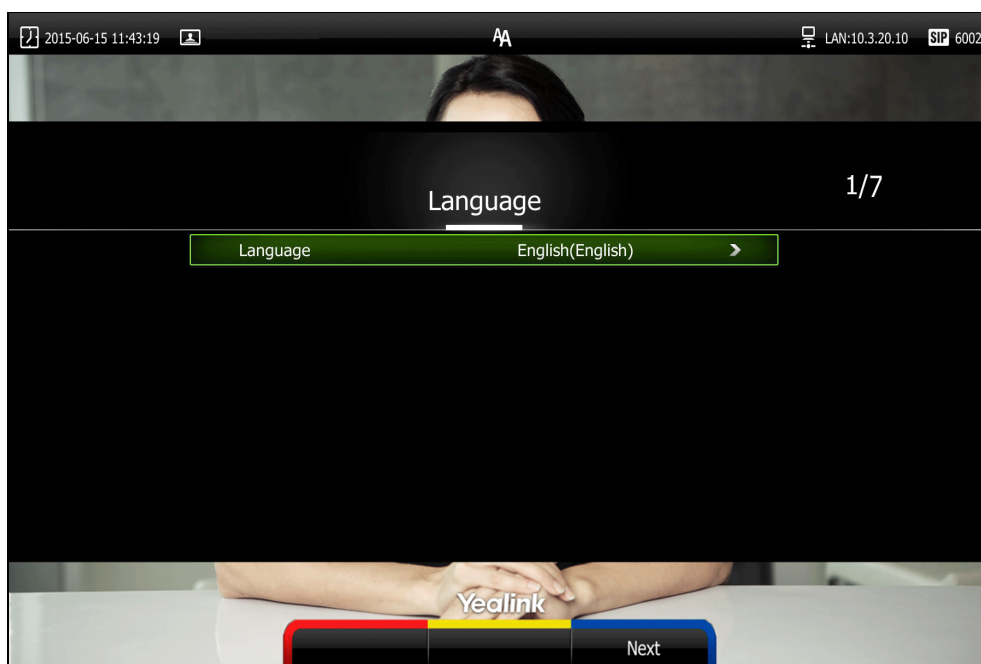

1. Set the language displayed on the display device.

The default language is English.



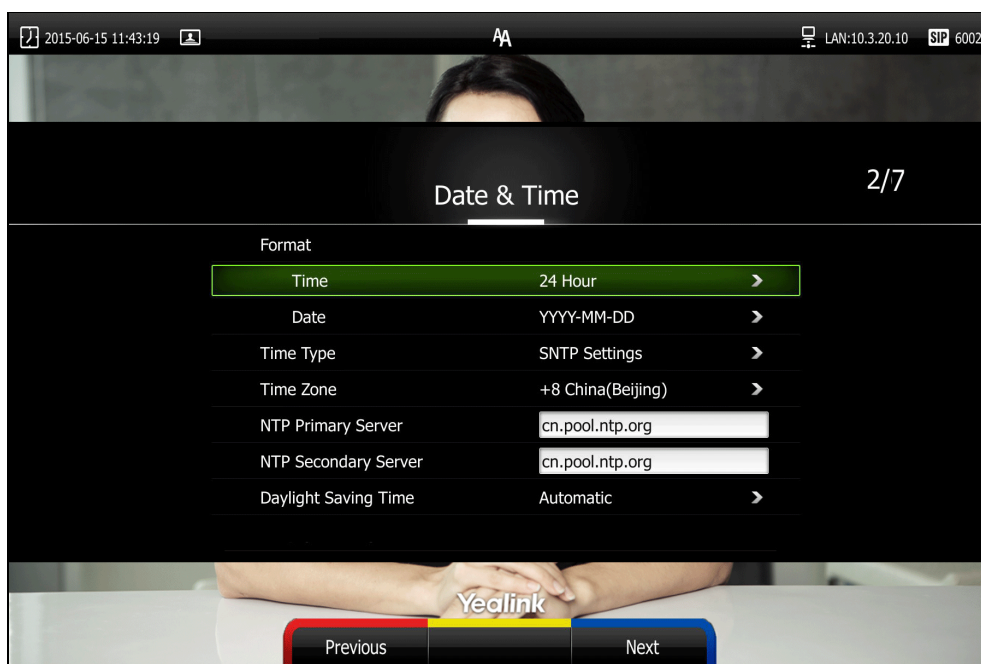

2. Press  (**Next** soft key) to continue.
3. Set the date and time.

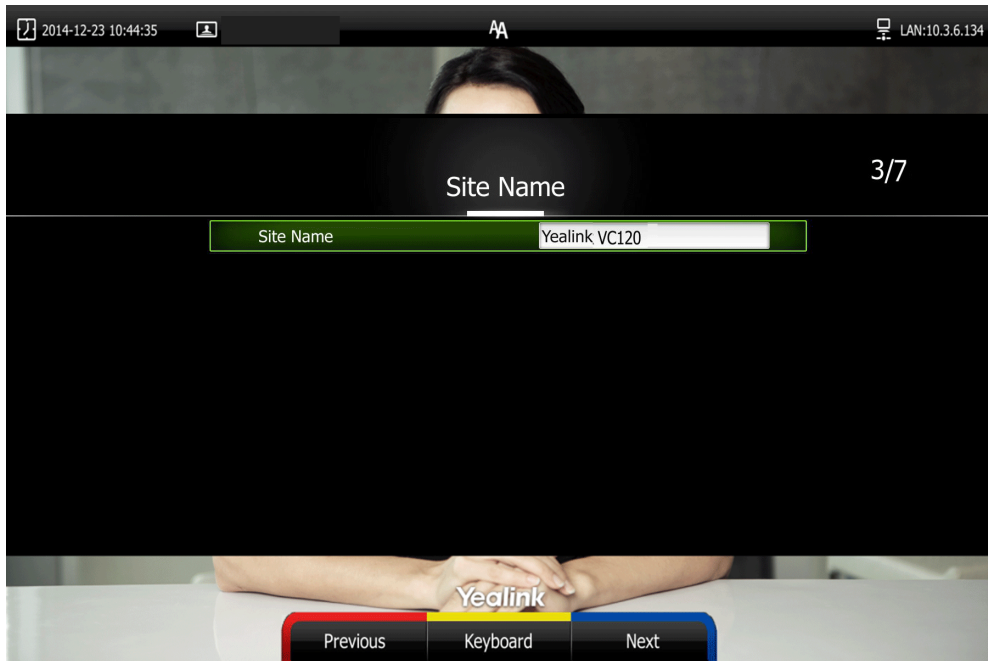

4. Press  (**Next** soft key) to continue or press  (**Previous** soft key) to return to the previous screen.
5. Edit the site name.

The default site name is "Yealink VC120".



6. Press  (**Next** soft key) to continue or press  (**Previous** soft key) to return to the previous screen.

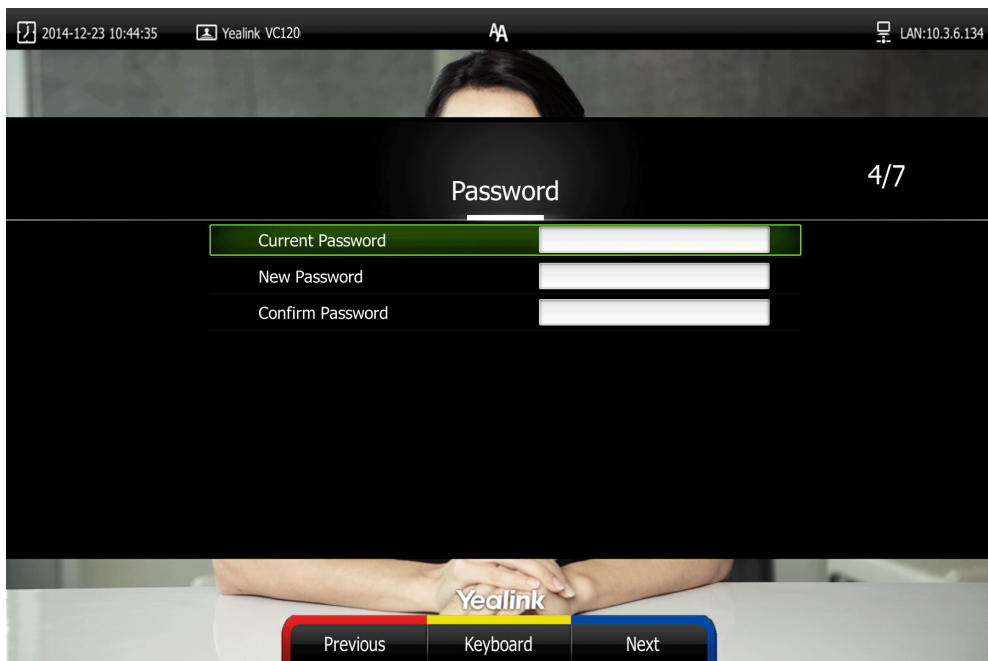

7. Change the administrator password.

The default administrator password is "0000".





Note

Do remember the new administrator password or keep a copy of the password in a safe place. If you forget the password, you will need to reset the system to the factory settings, and then reset the password or use the default password "0000".

8. Press  (**Next** soft key) to continue or press  (**Previous** soft key) to return to the previous screen.

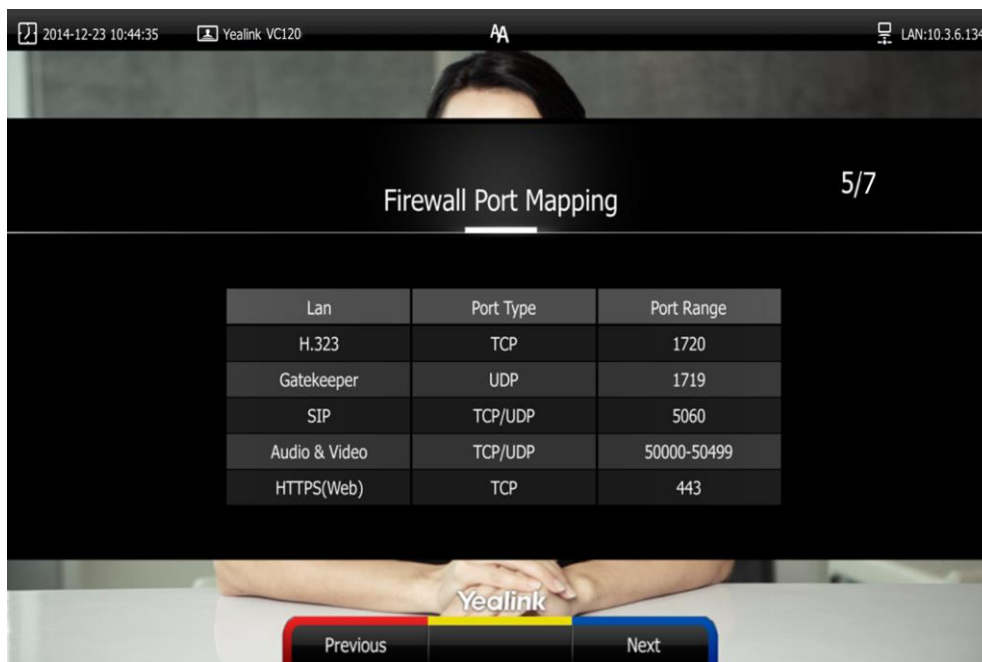
The display device shows firewall port mapping information.





9. Press  (**Next** soft key) to continue or press  (**Previous** soft key) to return to the previous screen.

10. Configure network settings.

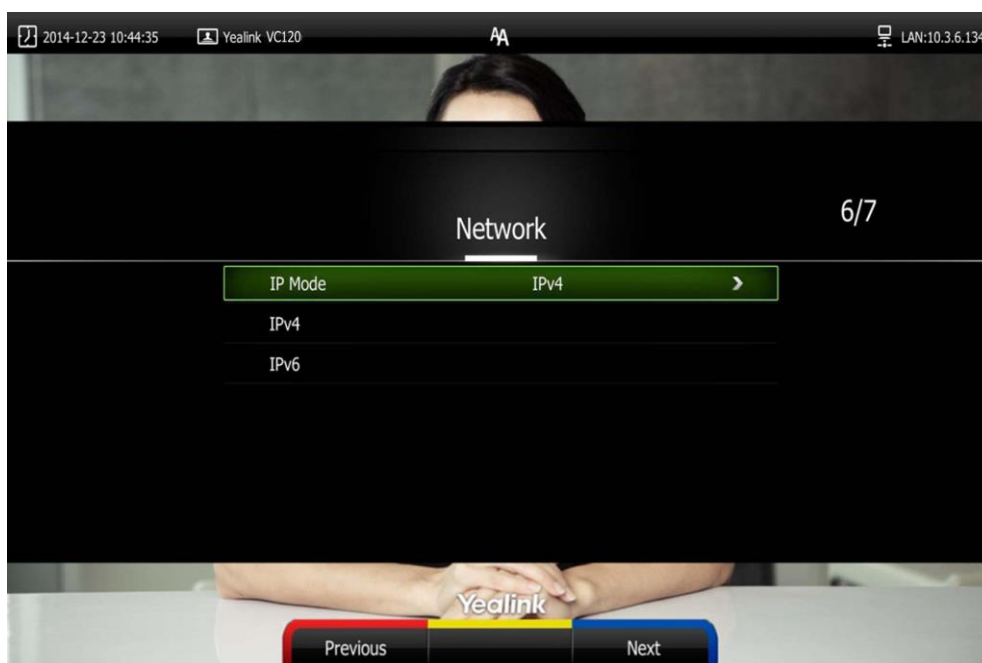
The phone will try to contact a DHCP server in your network to obtain network parameters by default. If you uncheck the DHCP checkbox, you will need to configure IPv4 or IPv6 network manually.



11. Press  (**Next** soft key) to continue or press  (**Previous** soft key) to return to the

previous screen.

12. (Optional) Log into the Cloud platform.

Yealink video conferencing system supports Yealink Cloud/StarLeaf/Zoom/Pexip/BlueJeans/Mind/Custom platform. For more information, refer to [Yealink VC400 & VC120 Video Conferencing System Administrator Guide](#).

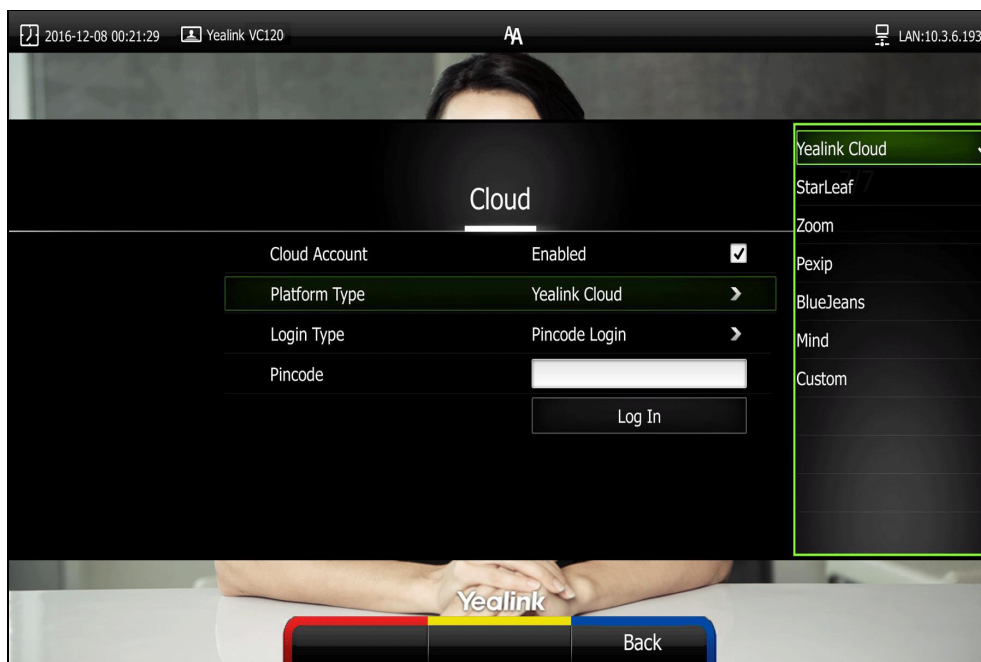

13. Press  (**Complete** soft key) to complete the setup wizard.

For more information on how to configure system features using the remote control, refer to [Navigating Menus on the Display Device](#) on page 49 and [Entering Data and Editing Fields](#) on page 51. For more information on how to configure language, time and date, refer to [Customizing the VC120 Video Conferencing System](#) on page 55.

Note

Wrong network settings may result in the inaccessibility of your system. They may also have an impact on your network performance. For more information on these parameters, contact your system administrator.

Registration

You can register the H.323 account, SIP account and log into the Cloud platform. The VC120 system is compatible with StarLeaf/Zoom/Pexip/BlueJeans/Mind platform. Generally, your system administrator will configure the account beforehand, so that after you start up the system, the system will already be registered and ready for use. If your system is not registered, you may have to register it. For more information on how to register an account for the system, refer to [Yealink VC400 & VC120 Video Conferencing System Administrator Guide](#).





Idle Screen Display

Idle screen of the display device

If the system starts up, the idle screen will be shown. The following figure is an example of the idle LCD screen:



Name	Description
Time and Date	The time and date are displayed on the left of the status bar.
Site name	The site name of the system. For more information on how to change the site name, refer to Site Name on page 57.
Status icon	Status icons are displayed in the center of the status bar. For more information on the status icon, refer to Icons on Display Device on page 29.
IP address	<ul style="list-style-type: none"> LAN: X.X.X.X: Indicates the system has obtained an IP address. Network disconnected: Indicates the system does not connect to an Ethernet cable. Please check the Ethernet cable.

Name	Description
	<ul style="list-style-type: none"> • 255.255.255.255: Indicates the system fails to obtain an IP address. Check the connection between the system and the DHCP server, or you can configure a static IP address for the system. For more information on how to configure a static IP address, refer to Setup Wizard on page 42.
Registered account	<p>When the VC120 system is registered with the SIP server, the account icon is . For more information, refer to Yealink VC400 & VC120 Video Conferencing System Administrator Guide.</p>
	<p>When the VC120 system is registered with an H.323 gatekeeper, the account icon is . For more information, refer to Yealink VC400 & VC120 Video Conferencing System Administrator Guide.</p>
	<p>When the VC120 system logs into a Yealink Cloud platform, the icon is .</p> <p>When the VC120 system logs into a StarLeaf/Zoom/Pexip/BlueJeans/Mind platform, the icon is . For more information, refer to Yealink VC400 & VC120 Video Conferencing System Administrator Guide.</p>
Video image	Video image is displayed.
Soft keys	The display device shows the names of shortcut keys, and users can press these shortcut keys on the remote control to execute corresponding action.

Idle screen of the video conferencing phone

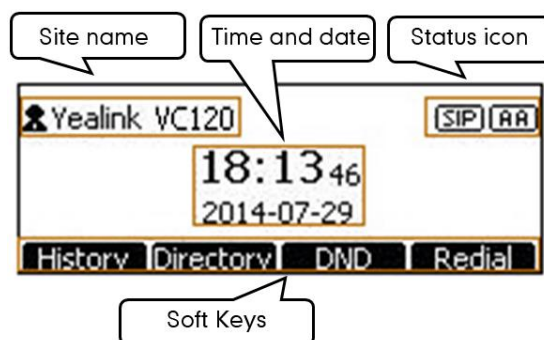

Name	Description
Status icon	Displays the phone's status icon.
Soft Keys	Displays four soft keys. <ul style="list-style-type: none"> • History: Enters the History screen • Directory: Enters the Directory screen • DND: Enables or disables the Do Not Disturb mode • Redial: Redials the last dialed number
Site name	Displays the site name.
Time and Date	Displays the time and date.





Navigating Menus on the Display Device



You can use the remote control to enter the main menu screen, and view the items on the display device.

Note

The system will automatically return to the idle screen after 60 seconds of inactivity.

To navigate menus and fields, you can:

If you want to	You can
Enter the main menu.	Press  (Menu soft key).
Return to the idle screen.	Press  .
Go back to the previous menu.	Press  (Back soft key) or  .
Navigate through menus.	Press ◀ or ▶ to select a menu. Press ▲ or ▼ to select an item.
Expand pull-down list.	Press  or ▶ to expand a pull-down list.

If you want to	You can
Select an option from the pull-down list.	From the pull-down list, Press ▲ or ▼ to scroll to the setting and then press  .
Enable or disable features.	Press  .

Keyboard Input Method

The on-screen keyboard supports English and Russian input methods.



You can enter characters using the input method only when the input method is enabled.

Changing keyboard input method is configurable via web user interface only.

To configure keyboard input method via web user interface:

1. Click on **Setting** ->**General**.
2. In the **Keyboard IME** block, select the desired list from the **Disabled** column and click  .

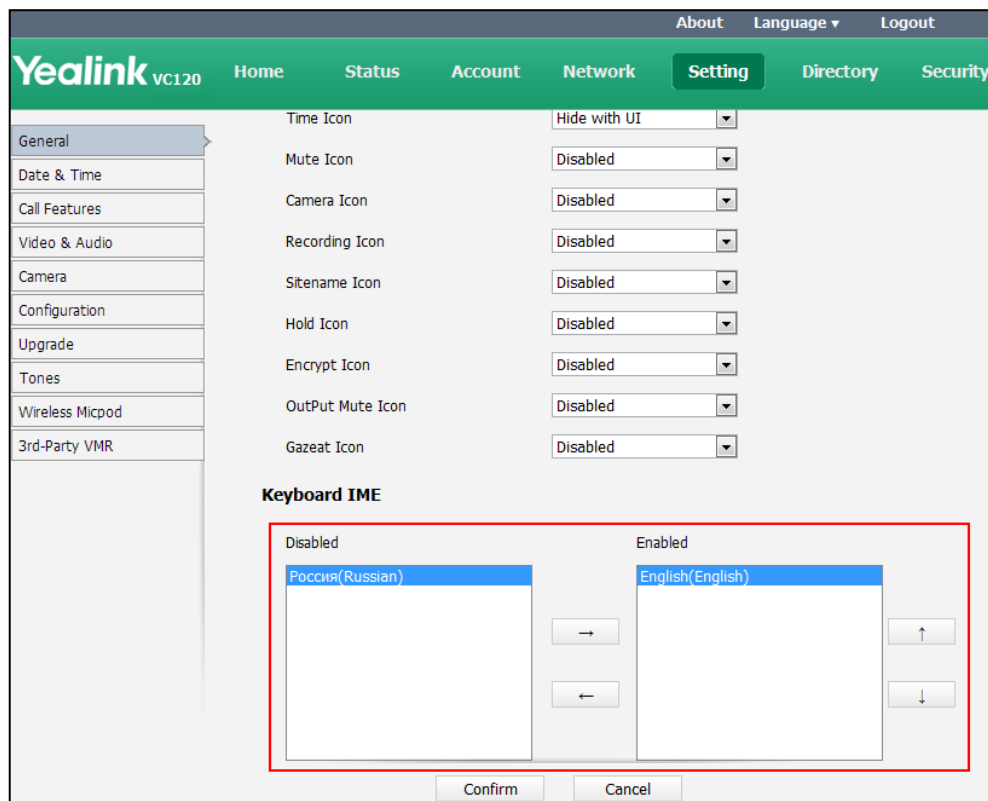

The selected input method appears in the **Enabled** column.

3. Repeat step 2 to add more input methods to the **Enabled** column.
4. (Optional.) To remove a list from the **Enabled** column, select the desired list and then click  .
5. To adjust the display order of the enabled input methods, select the desired list, and click  or  .



- Click **Confirm** to accept the change.

To change keyboard input method via the remote control:











- Press  (**Keyboard** soft key) or  (**Keyboard** soft key).
The display device displays the on-screen keyboard.
- Press  (**abc** soft key) to change the input method.



Entering Data and Editing Fields

You can enter data and edit fields using the keypad on the remote control or the on-screen keyboard on the display device:

To enter or edit data:

- Select the field.
- Do one of the following:

If you want to	You can
Entering numbers.	Press the digit keys on the remote control.
Entering letters.	<ol style="list-style-type: none"> Press  (Keyboard soft key) to open the on-screen keyboard. If the system is in the dialing screen, press  (Keyboard soft key) to open the on-screen keyboard. Press the navigation keys on the remote control to select desired letters. Press  (abc soft key) to switch input method. Press  . Press  (Exit Keyboard soft key) to exit from the on-screen keyboard.
Entering special characters.	<ol style="list-style-type: none"> Press  (Keyboard soft key) to open the on-screen keyboard. If the system is in the dialing screen, press  (Keyboard soft key) to open the on-screen keyboard. Press  (abc soft key) to switch the input method to @#%. Press the navigation keys on the remote control to select desired characters. Press  . Press  (Exit Keyboard soft key) to exit from the on-screen keyboard.

If you want to	You can
Delete text you entered.	<ul style="list-style-type: none"> • Press  to delete one character at a time. • Long press  for 2 seconds to delete the entire field of text.

3. Press  to save.

System Status

When the system is idle, you can view its status via the remote control, video conferencing phone or web user interface.

Available system status information includes:

- **System information** (device model, firmware, hardware version, product ID and serial number)
- **Network status** (LAN type, IP address, MAC, subnet mask, gateway and DNS server, public IP address can also be viewed if the static NAT is enabled)
- **Account status** (register status of SIP account, H.323 account and Cloud platform)
- **Camera** (status, device model, SPEC, hardware version and serial number)
- **Audio** (the active audio input and output devices)
- **VCS Phone** (status, device model, hardware version and serial number)
- **Wired Micpod** (status, model, hardware, serial number)
- **License** (8-way MCU license installation status)

To view the system status via the remote control:

1. Press  (**Menu** soft key).

The display device shows the **Status** menu.

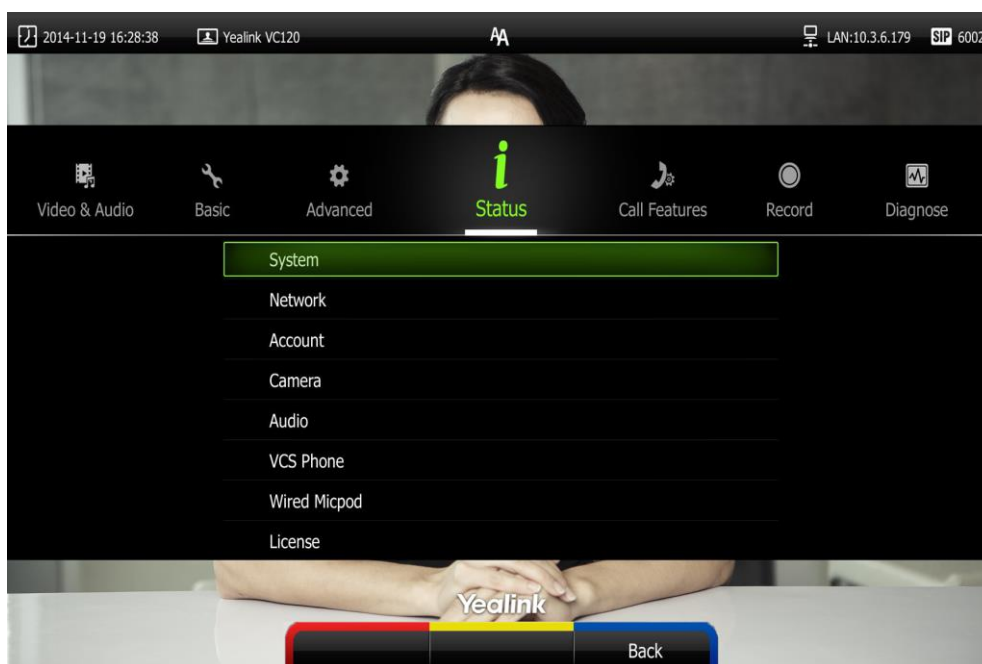

2. Press ▲ or ▼ to select the desired list.
3. Press  to view the specific information.

To view the system status via web user interface:

1. Click **Status**.

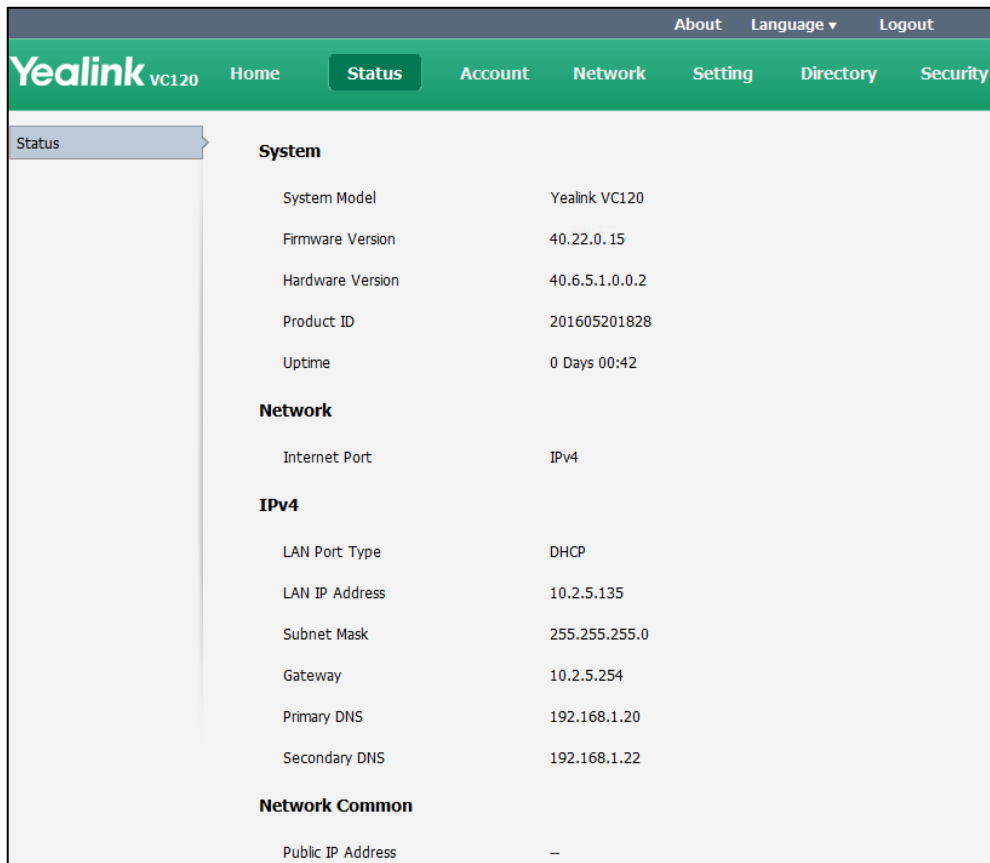

The system status is displayed on the web user interface.

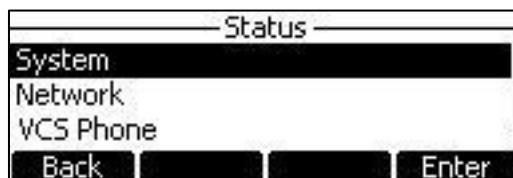

To view the system status via phone user interface:

1. Press .



2. Press  or  to select the desired list.
3. Press  or the **Enter** soft key to view the specific information.

Customizing the VC120 Video Conferencing System

You can customize your VC120 video conferencing system by personally configuring certain settings, for example, site name, time & date and language. You can add contacts to the local directory manually or from the call history.

This chapter provides basic operating instructions for customizing your system. Topics include:

- [General Settings](#)
- [Directory](#)
- [Call History Management](#)
- [Call Protocol](#)
- [Bandwidth Settings](#)
- [Audio Settings](#)
- [Far-end Camera Control](#)

If you require additional information or assistance with your new system, contact your system administrator.

General Settings



Automatic Sleep Time

The system will enter the sleep mode automatically when it has been inactive for a period of time (the default period is 10 minutes).

When the system is in sleep mode, it will still accept incoming calls. The display device will prompt "No Signal", and the video conferencing phone LCD screen prompts "Sleeping Press any key to resume". You can press any key on the remote control or video conferencing phone to wake the system up. When receiving a call, the system will be woken up automatically.

You can change the automatic sleep time via the remote control or web user interface. You can also press the sleep key on the remote control to make the system sleep immediately.

To configure the automatic sleep time via the remote control:

1. Press  (Menu soft key) to enter main menu.
2. Press ◀ or ▶ to select the **Basic** menu.
3. Press ▲ or ▼ to scroll to **Automatic Sleep Time**, and then press .
4. Select desired time from the pull-down list of **Automatic Sleep Time**.

If **Always On** is selected, the system will not enter the sleep mode automatically.

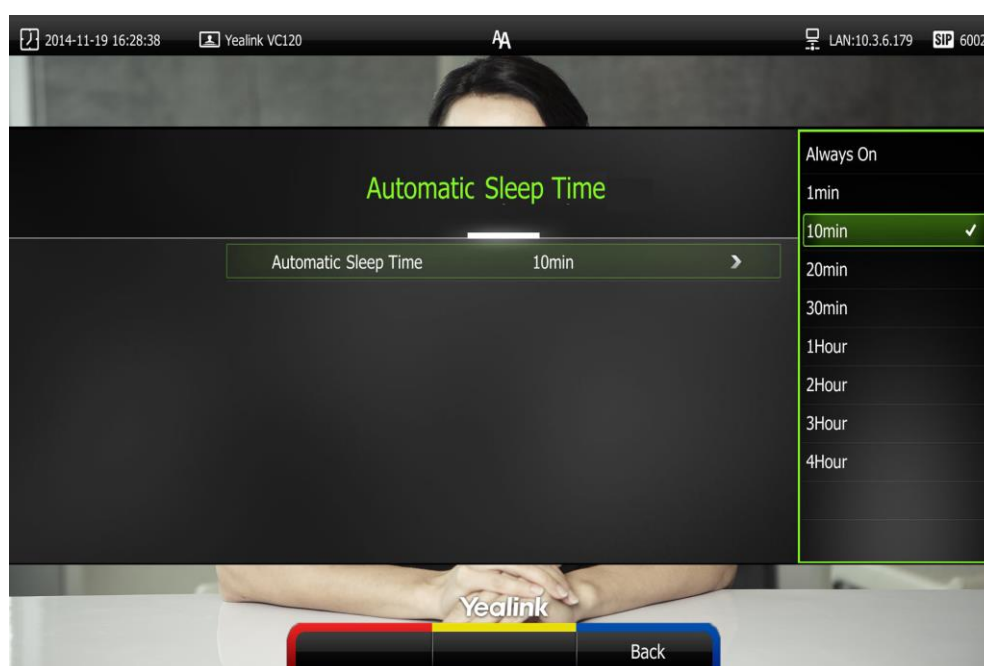

5. Press  (**Save** soft key) to accept the change.

Automatic sleep time is configurable via web user interface at the path **Setting->General->Automatic Sleep Time**.

Backlight

The backlight of the video conferencing phone is always on by default. You can configure backlight time for the video conferencing phone's LCD screen via web user interface.

You can configure the LCD screen's backlight time in the following formats:

- **Always On:** Backlight is on permanently.
- **15s, 30s, 1Min, 2 Min, 5 Min, 10 Min, 30 Min:** Backlight goes out when the phone has been inactive for the time you set.

To configure the backlight via web user interface:

1. Click on **Setting ->General**.

2. Select the desired value from the pull-down list of **Backlight Time**.

The screenshot shows the Yealink VC120 web interface. The top navigation bar includes 'About', 'Language', and 'Logout'. The main menu has 'Home', 'Status', 'Account', 'Network', 'Setting' (highlighted), 'Directory', and 'Security'. On the left, a sidebar lists various settings categories: General, Date & Time, Call Features, Video & Audio, Camera, Configuration, Upgrade, Tones, Wireless Micpod, and 3rd-Party VMR. The main content area is titled 'General Information' and contains several configuration items:

- Site Name: Yealink VC120
- Automatic Sleep Time: 10 Min
- Backlight Time: Always On** (highlighted with a red box)
- Hide IP Address: Disabled
- ReLogOffTime(1-1000min): 5
- Key Tone: On

Below this is the 'Meeting Password' section, which includes a 'Meeting Password' dropdown set to 'Off' and a 'Password' input field.

3. Click **Confirm** to accept the change.

Site Name

Site name is displayed on the status bar of the display device and video conferencing phone. You can make an IP address call to the other party, the system site name will be displayed on the remote display device. Site names can consist of letters, numbers or special characters. Site name is configurable via the remote control or web user interface.

To configure the site name via the remote control:

1. Press  (Menu soft key) to enter main menu.
2. Press ◀ or ▶ to select the **Basic** menu.
3. Press ▲ or ▼ to scroll to **Site Name**.

4. Edit the site name.

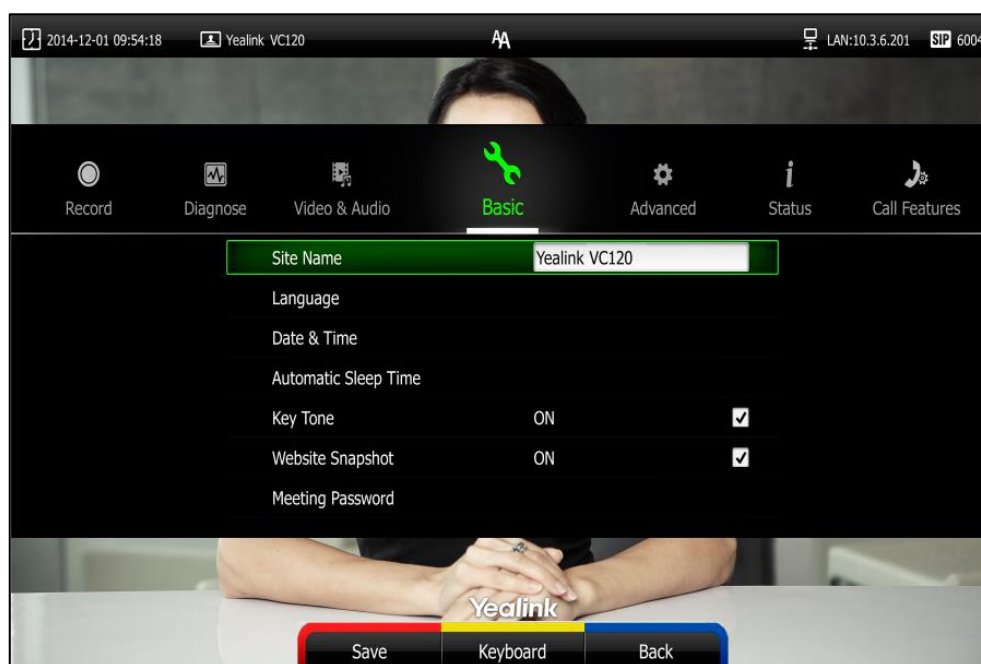

5. Press  (**Save** soft key) to accept the change.



Site name is configurable via web user interface at the path **Setting->General->Site Name**.

Language

The default language of the display device is English, and you can change it via the remote control. The video conferencing phone will detect and use the same language as which of the display device.

The default language of the web user interface is English. You can change the web user interface language for web user interface. The available languages for the system are English, Chinese Simplified, Chinese Traditional, French, German, Italian, Polish, Portuguese, Spanish, Turkish, Russian and Czech.

To change the language for the display device via the remote control:

1. Press  (**Menu** soft key) to enter main menu.
2. Press ◀ or ▶ to select the **Basic** menu.
3. Press ▲ or ▼ to scroll to **Language**, and then press .

4. Select the desired language from the pull-down list of **Language**.



5. Press  (**Save soft key**) to accept the change.

Text displayed on the display device and LCD screen of video conferencing phone will change to the selected language.

To change the language for the web user interface:

1. Click on **Language** at the top right corner of the web page.
2. Select the desired language from the pull-down list of **Language**.

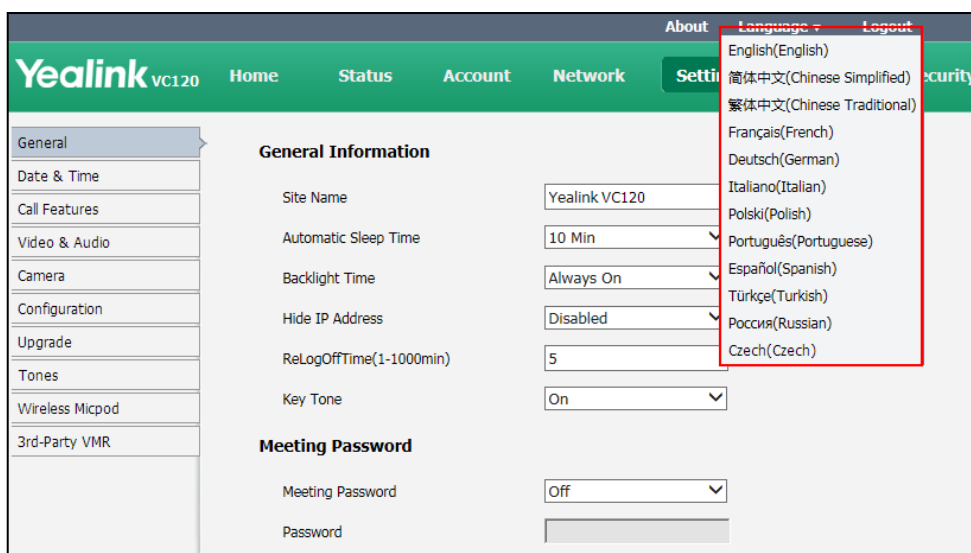

Text displayed on the web user interface will change to the selected language.

Time & Date

The time and date are displayed on the LCD screen of the video conferencing phone and display device. You can configure the system to obtain the time and date from the SNTP (Simple Network Time Protocol) server automatically. The SNTP allows the system to synchronize time to a main server. This keeps all network machine clocks on the same time. Enter the NTP Server name that you want to follow.



If the system cannot obtain the time and date from the SNTP server, you can configure the time and date manually, or contact your system administrator for more information.

There are 7 available date formats. For example, for the date format "WWW DD MMM", "WWW" represents the abbreviation of week. "DD" represents the two-digit day, and "MMM" represents the first three letters of the month.

The available date formats you need to know are:

Date Format	Example (2016-11-22)
WWW MMM DD	Tue Nov 22
DD-MMM-YY	22-Nov-16
YYYY-MM-DD	2016-11-22
DD/MM/YYYY	22/11/2016
MM/DD/YY	11/22/16
DD MM YYYY	22 Nov 2016
WWW DD MMM	Tue 22 Nov

To configure the NTP server and date & time format via the remote control:

1. Press  (Menu soft key) to enter main menu.
2. Press ◀ or ▶ to select the **Basic** menu.
3. Press ▲ or ▼ to scroll to **Date & Time**, and then press .
4. Select the desired time format from the pull-down list of **Time**.
5. Select the desired date format from the pull-down list of **Date**.
6. Select **SNTP Settings** from the pull-down list of **Time Type**.
7. Select the time zone that applies to your area from the pull-down list of **Time Zone**.
The default time zone is "+8 China(Beijing)".
8. Enter the domain names or IP addresses in the **NTP Primary Server** and **NTP Secondary Server** fields respectively.
9. Select the desired value from the **Daylight Saving Time** field.

When **Automatic** is selected, the system will use daylight saving time corresponding to the selected time zone.

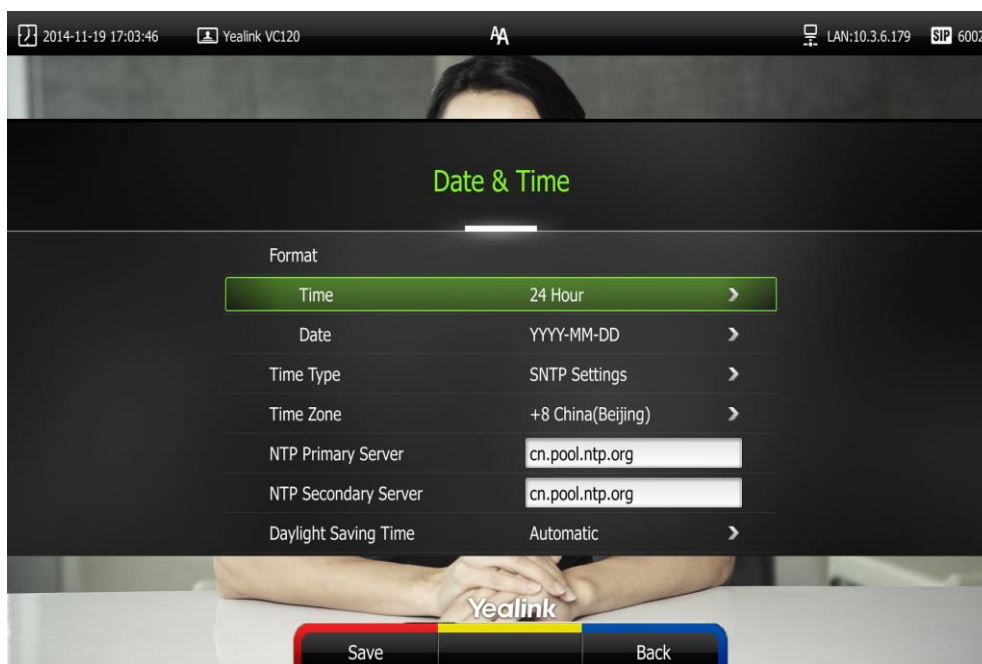



10. Press  (**Save** soft key) to accept the change.

Note

Please refer to [Appendix A - Time Zones](#) for the list of available time zones on the system.

To configure the time and date manually via the remote control:

1. Press  (**Menu** soft key) to enter main menu.
2. Press ◀ or ▶ to select the **Basic** menu.
3. Press ▲ or ▼ to scroll to **Date & Time**, and then press .
4. Select the **Manual Settings** from the pull-down list of **Time Type**.
5. Select the desired year from the pull-down list of **Year**.
6. Select the desired month from the pull-down list of **Month**.
7. Select the desired day from the pull-down list of **Day**.
8. Select the desired hour from the pull-down list of **Hour**.
9. Select the desired minute from the pull-down list of **Minute**.

10. Select the desired second from the pull-down list of **Second**.

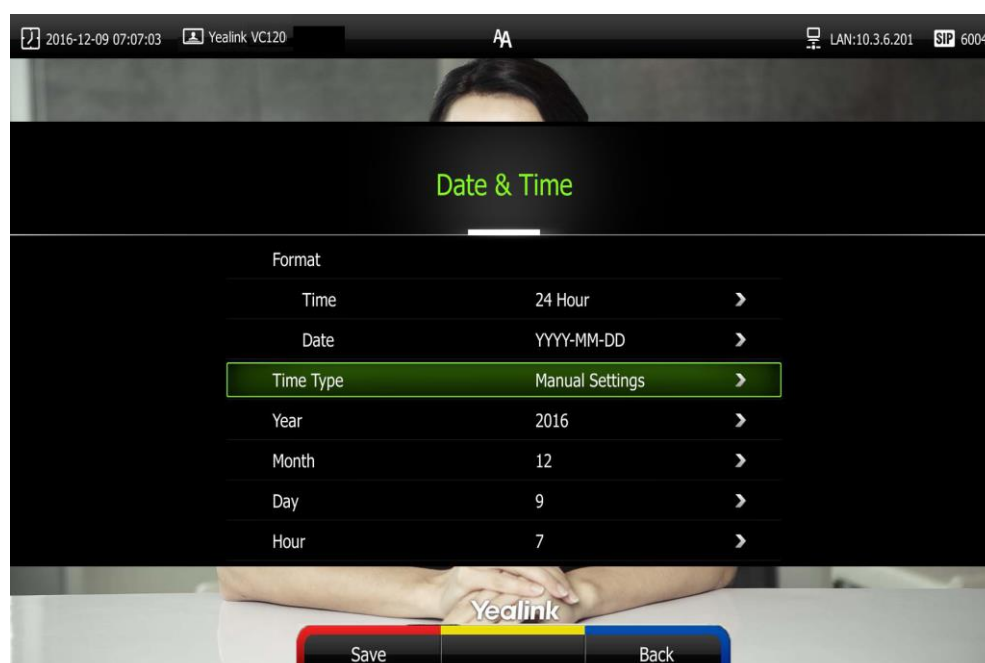

11. Press  (**Save** soft key) to accept the change.

Time and date is configurable via web user interface at the path **Setting->Date&Time**.

Key Tone

You can enable the key tone feature to play a key tone when you press any key on the remote control.

Key tone is configurable via the remote control or web user interface. Key tone feature is enabled by default.

Note If ringer volume is adjusted to 0, you cannot hear the key tone. For more information on how to adjust the ringer volume, refer to [Volume Settings](#) on page 64.

To configure the key tone via the remote control:

1. Press  (**Menu** soft key) to enter main menu.
2. Press ◀ or ▶ to select the **Basic** menu.

3. Press ▲ or ▼ to scroll to **Key Tone**, and then press **OK** to enable or disable this feature.

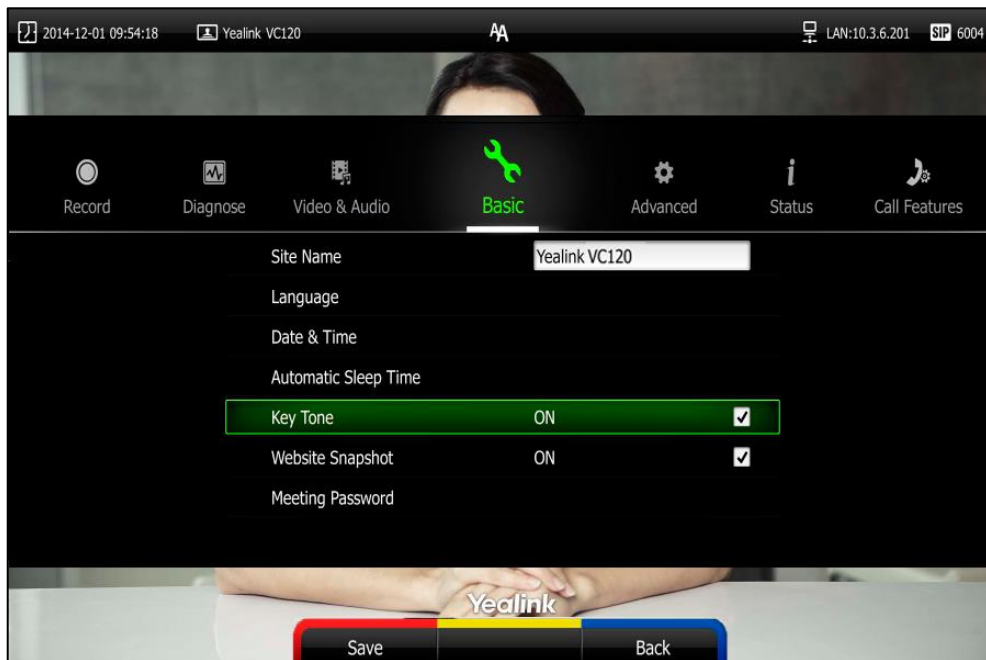

4. Press **Save** (Save soft key) to accept the change.

Key tone is configurable via web user interface at the path **Setting->General->Key Tone**.

Website Snapshot

You can enable the website snapshot feature to allow the user to watch video images captured by local camera on the web user interface.

Website snapshot is configurable via the remote control only and it is enabled by default.

To configure the website snapshot via the remote control:

1. Press **Menu** (Menu soft key) to enter main menu.
2. Press **Left** or **Right** to select the **Basic** menu.

3. Press ▲ or ▼ to scroll to **Website Snapshot**, and then press **OK** to enable or disable this feature.

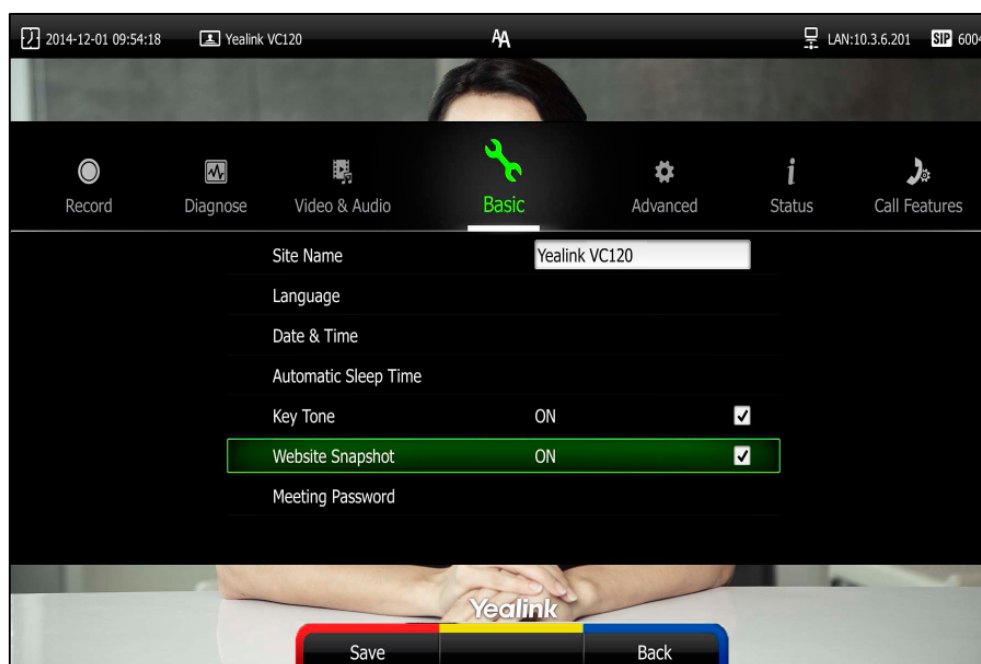

4. Press **Save** (Save soft key) to accept the change.

To watch video images via the web user interface at the path **Home**.

Volume Settings

You can use the remote control or video conferencing phone to adjust the ringer volume of the system when it is idle or ringing. You can also adjust the receiver volume of engaged audio devices when the system is in use.

To adjust the volume when the system is idle or ringing:

Do one of the following:

- Press **Volume Down** or **Volume Up** on the remote control to adjust the ringer volume of the system.

The current ringer volume of the system is displayed on the left of the display device.

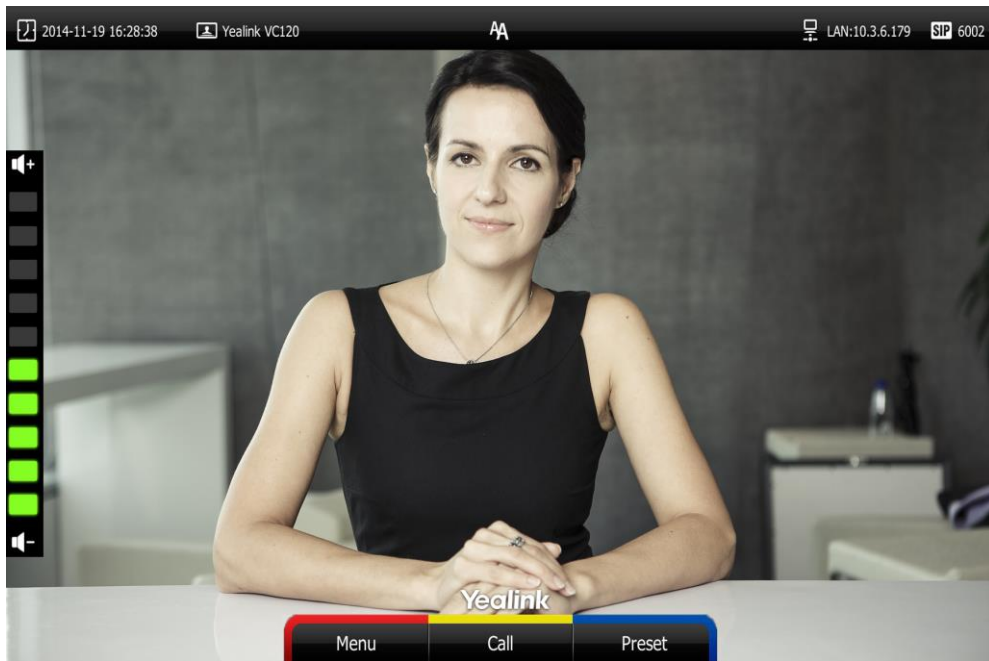

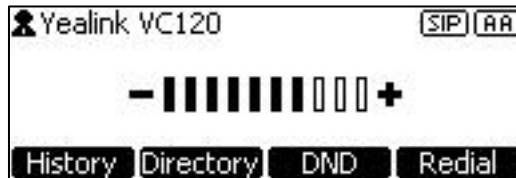

- Press  on the video conferencing phone to adjust the ringer volume. The LCD screen of the video conferencing phone displays the current ringer volume.





The display device will display the ringer volume simultaneously.

Note

If ringer volume is adjusted to 0, the  icon will appear on the display device. The  icon will appear on the LCD screen of the video conferencing phone.

To adjust the volume when the system during a call:

- Press  or  on the remote control to adjust the receiver volume of the system.

The current receiver volume of the system is displayed on the left of the display device.



- Press  to adjust the receiver volume.

The LCD screen of the video conferencing phone displays the current receiver volume.

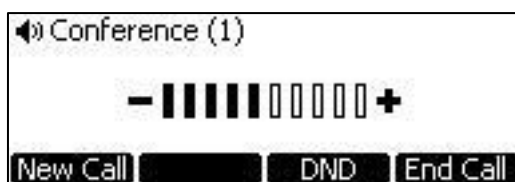

The display device will display the receiver volume simultaneously.

Note

If the video conferencing phone is not the active audio device of the system, you can still use it to adjust the system volume.

Meeting Password



If an 8-way conference license is imported to your VC120 video conference system, you can use meeting password to manage the incoming calls. For more information on how to import an 8-way conference license, refer to [8-Way Conference License](#) on page 130.

If you enable this feature, only the people who know the meeting password can dial your system. If your system is idle, meeting password can prevent people from dialing your system. If your system is during a call or conducting a conference call, meeting password can prevent unauthorized people from joining.

Note

You can add specified users to the meeting whitelist. Users in the whitelist can dial your system directly without meeting password. For more information on meeting whitelist, refer to [Meeting Whitelist](#) on page 68.

To configure the meeting password via the remote control:

1. Press  (**Menu** soft key) to enter main menu.
2. Press ◀ or ▶ to select the **Basic** menu.
3. Press ▲ or ▼ to scroll to **Meeting Password**, and then press .

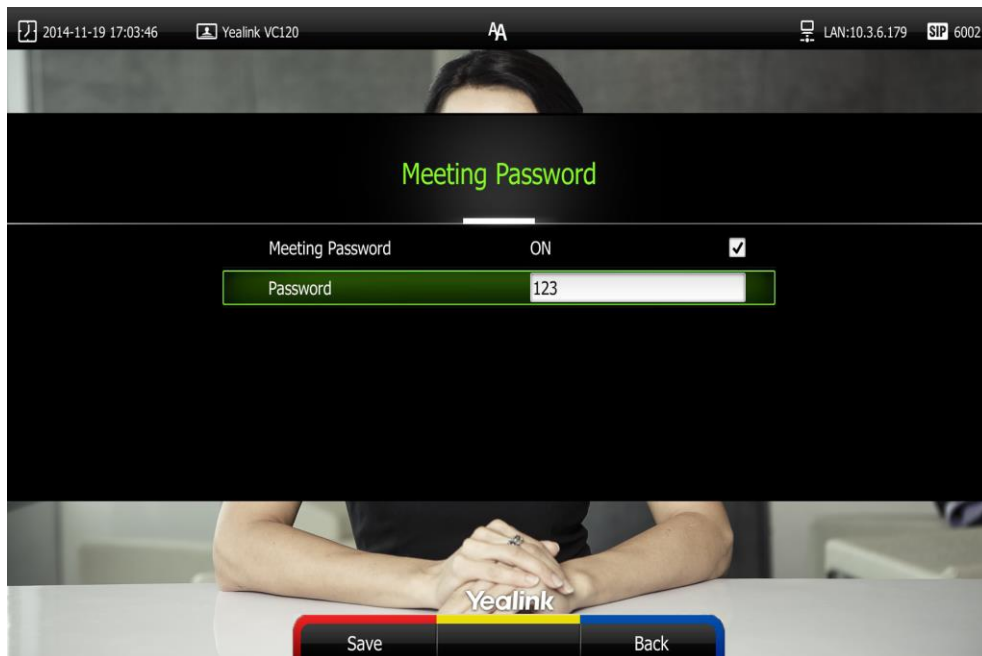

4. Check the **Meeting Password** checkbox.
5. Enter the meeting password in the **Password** field.
6. Press  (**Save** soft key) to accept the change.

Meeting password is configurable via web user interface at the path **Settings->General->Meeting Password**.

People can press **IP##meeting password** or **meeting password@IP** to dial your system or join your conference call. For example: your IP address is 10.3.6.179 and you set 123 as your meeting password. People should press **10.3.6.179##123** or **123@10.3.6.179** to dial your system or join your conference call. If people call you without a meeting password or with a wrong meeting password, the call will fail.

Meeting Whitelist

If an 8-way conference license is imported to your VC120 video conference system, you can add the IP address, account or domain name of the remote system to the meeting whitelist. Users in the whitelist can dial your system or join your conference call directly without meeting password even if you have enabled the meeting password feature. VC120 video conferencing system supports up to 100 whitelist records. Meeting whitelist is configurable via web user interface only. For more information on how to import an 8-way conference license, refer to [8-Way Conference License](#) on page 130.

To add the meeting whitelist numbers via web user interface:

1. Click on **Directory**->**Meeting Whitelist**.
2. Enter the user's IP, account or domain name in the **Meeting Whitelist Number** field.

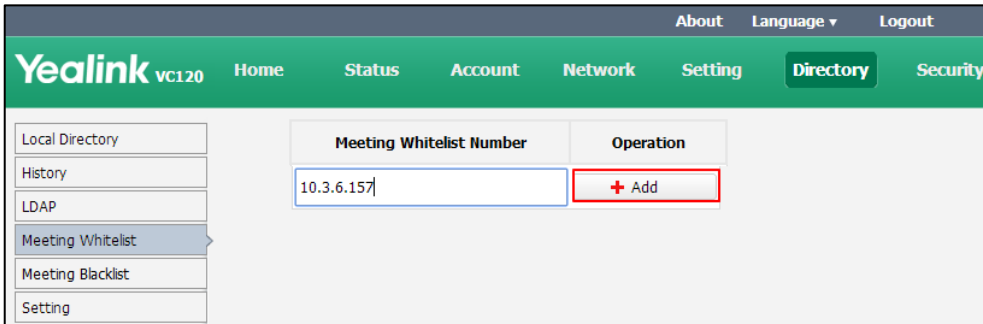

The screenshot shows the Yealink VC120 web interface. The top navigation bar includes 'About', 'Language', and 'Logout'. Below it, a green header contains 'Yealink VC120' and navigation links: 'Home', 'Status', 'Account', 'Network', 'Setting', 'Directory', and 'Security'. A sidebar on the left lists 'Local Directory', 'History', 'LDAP', 'Meeting Whitelist', 'Meeting Blacklist', and 'Setting'. The main content area has a table with two columns: 'Meeting Whitelist Number' and 'Operation'. The first row shows '10.3.6.157' in the first column and a '+ Add' button in the second column, which is highlighted with a red box.

3. Click **Add**.
4. Repeat step 2-3 to add more numbers to the whitelist.

To delete the meeting whitelist numbers via web user interface:

1. Click on **Directory**->**Meeting Whitelist**.
2. Click **Delete** beside the numbers that you want to delete.

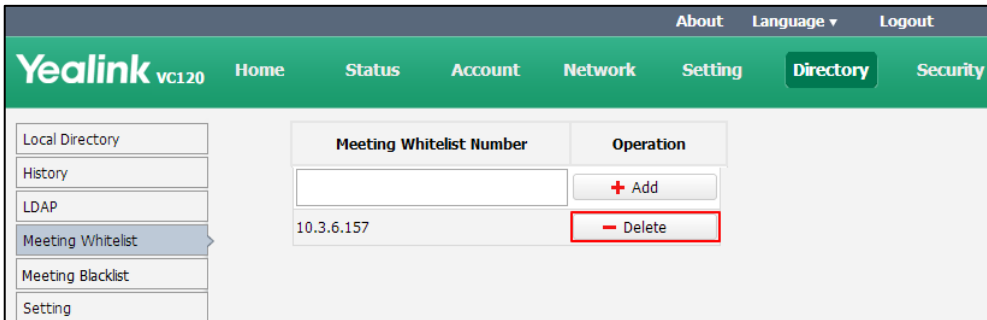

The screenshot shows the Yealink VC120 web interface. The top navigation bar includes 'About', 'Language', and 'Logout'. Below it, a green header contains 'Yealink VC120' and navigation links: 'Home', 'Status', 'Account', 'Network', 'Setting', 'Directory', and 'Security'. A sidebar on the left lists 'Local Directory', 'History', 'LDAP', 'Meeting Whitelist', 'Meeting Blacklist', and 'Setting'. The main content area has a table with two columns: 'Meeting Whitelist Number' and 'Operation'. The first row shows '10.3.6.157' in the first column and a '- Delete' button in the second column, which is highlighted with a red box.

The web user interface prompts the message "Warning: Are you sure delete the white number?".

3. Click **Confirm**.

Meeting Blacklist

You can add the IP address, account or domain name of the remote system to the meeting blacklist. VC120 will refuse incoming calls from the blacklist automatically. If the user is in both meeting whitelist and meeting blacklist, the blacklist has higher priority. VC120 will still refuse incoming calls from this user. VC120 will not remind incoming calls and save call history from blacklist.

VC120 supports up to 100 blacklist records. Blacklist is configurable via web user interface only.

To add the blacklist numbers via web user interface:

1. Click on **Directory**->**Meeting Blacklist**.
2. Enter the user's IP address, account or domain name in the **Meeting Blacklist Number** field.

The screenshot shows the Yealink VC120 web interface. The navigation menu includes 'About', 'Language', and 'Logout'. The main menu has 'Home', 'Status', 'Account', 'Network', 'Setting', 'Directory', and 'Security'. The 'Directory' menu is expanded, showing 'Local Directory', 'History', 'LDAP', 'Meeting Whitelist', 'Meeting Blacklist', and 'Setting'. The 'Meeting Blacklist' option is selected. The main content area has a table with two columns: 'Meeting Blacklist Number' and 'Operation'. The 'Meeting Blacklist Number' field contains the text '10.3.6.158'. To the right of this field is a button with a red plus sign and the text '+ Add'.

3. Click **Add**.
4. Repeat step 2-3 to add more numbers to the meeting blacklist.

To delete the blacklist numbers via web user interface:

1. Click on **Directory**->**Meeting Blacklist**.
2. Click **Delete** beside the numbers that you want to delete.

The screenshot shows the Yealink VC120 web interface. The navigation menu includes 'About', 'Language', and 'Logout'. The main menu has 'Home', 'Status', 'Account', 'Network', 'Setting', 'Directory', and 'Security'. The 'Directory' menu is expanded, showing 'Local Directory', 'History', 'LDAP', 'Meeting Whitelist', 'Meeting Blacklist', and 'Setting'. The 'Meeting Blacklist' option is selected. The main content area has a table with two columns: 'Meeting Blacklist Number' and 'Operation'. The 'Meeting Blacklist Number' field contains the text '10.3.6.158'. To the right of this field is a button with a red minus sign and the text '- Delete'.









The web user interface prompts the message "Warning: Are you sure delete the black number?".

3. Click **Confirm**.

Hiding Icons in a Call

During a call, the system will display some information and icons (such as call time, mute icon and recording icon) by default, you can know the call status from these information and icons. You can also hide these icons as needed to achieve the best video effects. Hiding icons in a call feature is configurable via web user interface only.

To enable the hiding icons in a call feature via web user interface:

1. Click on **Setting->General**.
2. Select the desired values from the pull-down lists of **Time Icon** (), **Mute Icon** (), **Camera Icon** (), **Recording Icon** (), **Sitename Icon**, **Hold Icon** (), **Encrypt Icon** (), **OutPut Mute Icon** (), and **Gazeat Icon** ().
 - If you select **Disabled**, the system does not display corresponding icons during a call.
 - If you select **Hide with UI**, the system displays corresponding icons during a call, but the icons will hide with UI.
 - If you select **Enabled**, the system displays corresponding icons during a call.

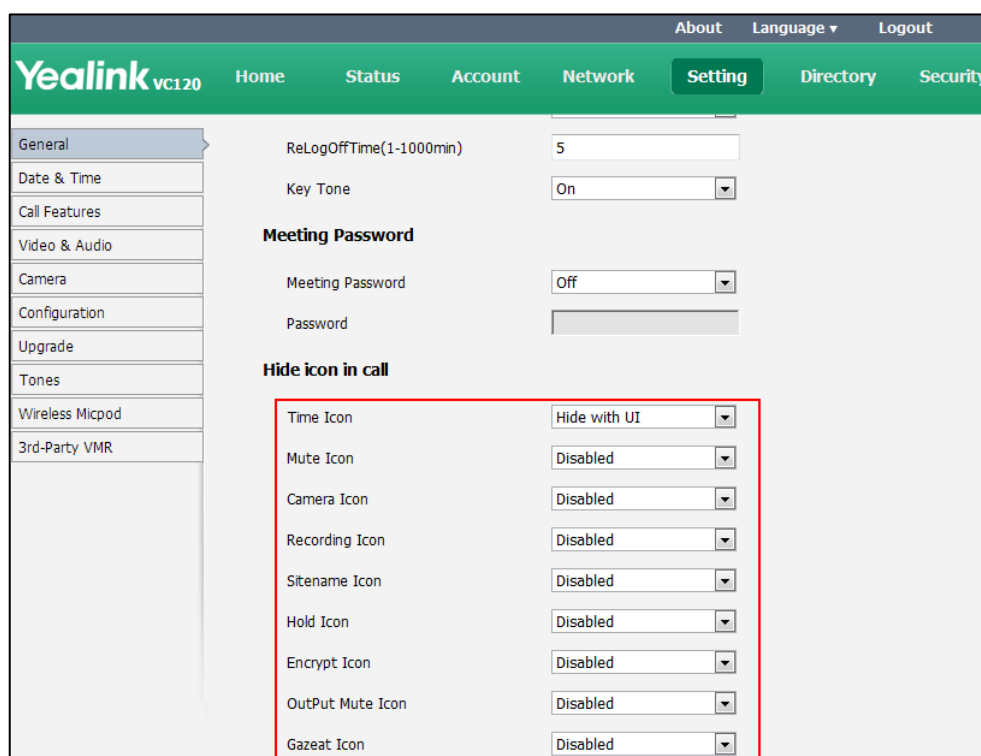

3. Click **Confirm** to accept the change.

USB Configuration

If you have high requirement for data security, you can disable the USB feature. If you disable the USB feature, you cannot view the videos and screenshots stored in the USB flash driver via

the remote control, and cannot record video or capture screenshots too.

To configure USB configuration via web user interface:

1. Click on **Setting-> Video & Audio**.
2. Select the desired value from the pull-down list of **USB Enable**.

The screenshot shows the Yealink VC120 web management interface. The 'Setting' menu is active, and the 'Video & Audio' sub-menu is selected. The 'USB Config' section at the bottom of the settings page is highlighted with a red box, showing the 'USB Enable' dropdown menu set to 'Disabled'. Other visible settings include 'Mix' (On), 'Far-end Camera Control' (Not FECC in call(0~300s): 15, Far Control Near Camera: Enabled, Far Set of Camera Presets: Disabled, Far Move to Camera Presets: Disabled), 'Output Resolution' (Display1: Auto(1920 x 1080 60H, Display2: No devices), and 'Record' (Recording: Enabled, Auto Recording: Disabled, Screenshot: Enabled). 'Confirm' and 'Cancel' buttons are visible at the bottom.

3. Click **Confirm** to accept the change.

Directory

VC120 system can store up to 500 local contacts. You can add multiple numbers for a local contact (at most 3).

You can import or export local contact list to different systems to share the local directory. The system only supports the XML and CSV format contact lists. You can view local directory via web user interface, remote control and the video conferencing phone. But you can edit or delete the local directory via web user interface and remote control.

If you log into the Yealink Cloud platform, Yealink Cloud contacts will display in your directory menu. Yealink Cloud contacts are created by your Yealink Cloud enterprise administrator. Only Yealink Cloud enterprise administrator can add, edit and delete Yealink Cloud contacts on the Yealink web management service, these operations will update to VC120 automatically. You do not have the permission to do the operations on the VC120. You can only search and place calls to the Yealink Cloud contacts. For more information on Yealink web management service, refer

to [Yealink VC Cloud Management Service Administrator Guide](#).

Note

Starleaf/Zoom/BlueJeans/Pexip/Mind platform does not provide Cloud contacts for video conferencing System.



This chapter provides operating instructions for the directory. Topics include:

- [Adding Local Contacts](#)
- [Placing Calls to Contacts](#)
- [Editing Local Contacts](#)
- [Deleting Local Contacts](#)
- [Searching for Contacts](#)
- [Search Source List in Dialing](#)
- [Importing/Exporting Contact Lists](#)

Adding Local Contacts

You can add local contacts to the system via the remote control or web user interface.

To add a local contact via the remote control:

1. Press  (**Call** soft key).
2. Press ◀ or ▶ to select the **Directory** menu.
3. Press  (**New Contact** soft key).
4. Enter contact name in the **Name** field.
5. Enter contact number or IP address in the **Number** field.
6. Press ▲ or ▼ to scroll to **Add New Number**, and then press  to add more numbers.
Up to 3 numbers can be added to a contact.
7. Enter the second number of the contact in the **Number 2** field.
You can repeat step 6 to add the third number to the contact, and enter the third number in the **Number 3** field.
8. Select the desired contact bandwidth from the pull-down list of **Bandwidth**.

The default contact bandwidth is **Auto**. The system will select the appropriate bandwidth automatically.

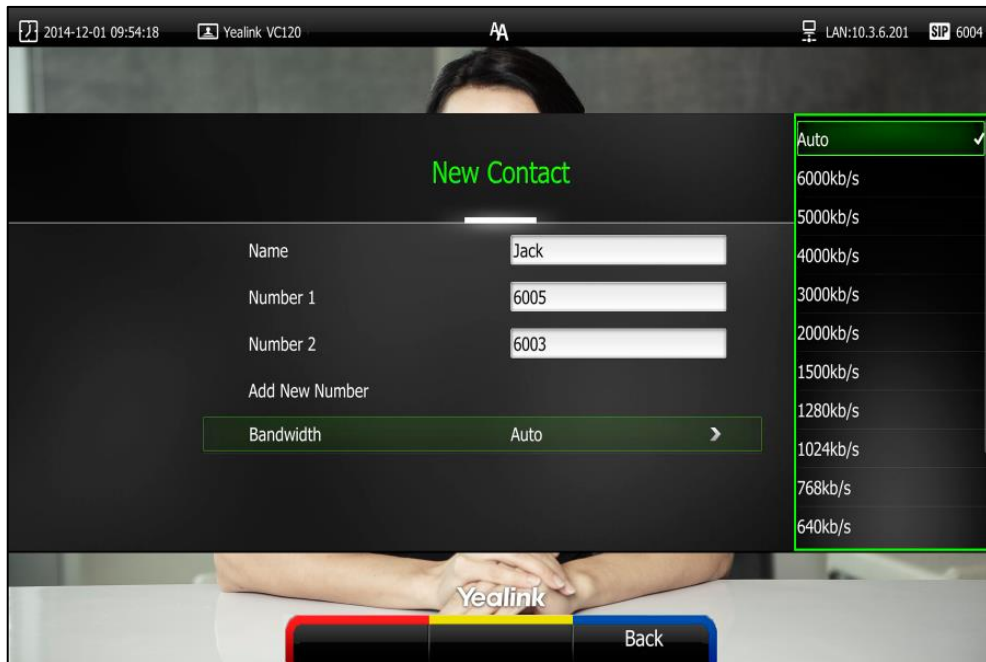

9. Press  (**Save** soft key) to save the local contact.

Note





If the contact already exists in the directory, the display device will prompt "Contact already exists!".

You can also add contacts via web user interface at the path **Directory->Local Directory**.















Placing Calls to Contacts

You can place calls to local contacts via the remote control, video conferencing phone or web user interface. If you log into the Yealink Cloud platform, you can also place calls to Cloud contacts.

To place a call to a contact via the remote control:

1. Press  (**Call** soft key).
2. Press ◀ or ▶ to select the **Directory** menu.
3. Select the desired contact type from the pull-down list of the **All Contacts** first.
4. Press ▲ or ▼ to select the desired local contact.
5. Press  .
 - If only one number is stored for the contact, the contact number will be dialed out directly.
 - If multiple numbers are stored for the contact, press ▲ or ▼ to highlight the desired number, and then press  or .







To place a call to a contact via the video conferencing phone:

1. Press the **Directory** soft key to enter the Directory list.
2. Press  or  to select the desired directory list.
3. Press the **Enter** soft key or  to view the contacts in the selected directory.
4. Press  or  to select the desired contact.
You can press the  or  soft key to switch the directory list.
5. Do one of the following:
 - If only one number is stored for the contact, press the **Send** soft key,  or  to call the contact.
 - If multiple numbers are stored for the contact, press the **Enter** soft key or  to view the contact numbers.
Press  or  to highlight the desired number.
Press the **Send** soft key,  or  to call the contact.

Editing Local Contacts



You can edit local contacts via the remote control or web user interface:

To edit a local contact via the remote control:

1. Press  (**Call** soft key).
2. Press  or  to select the **Directory** menu.
3. Press  or  to select the desired local contact.
4. Press  (**Detail** soft key).
5. Edit contact information.

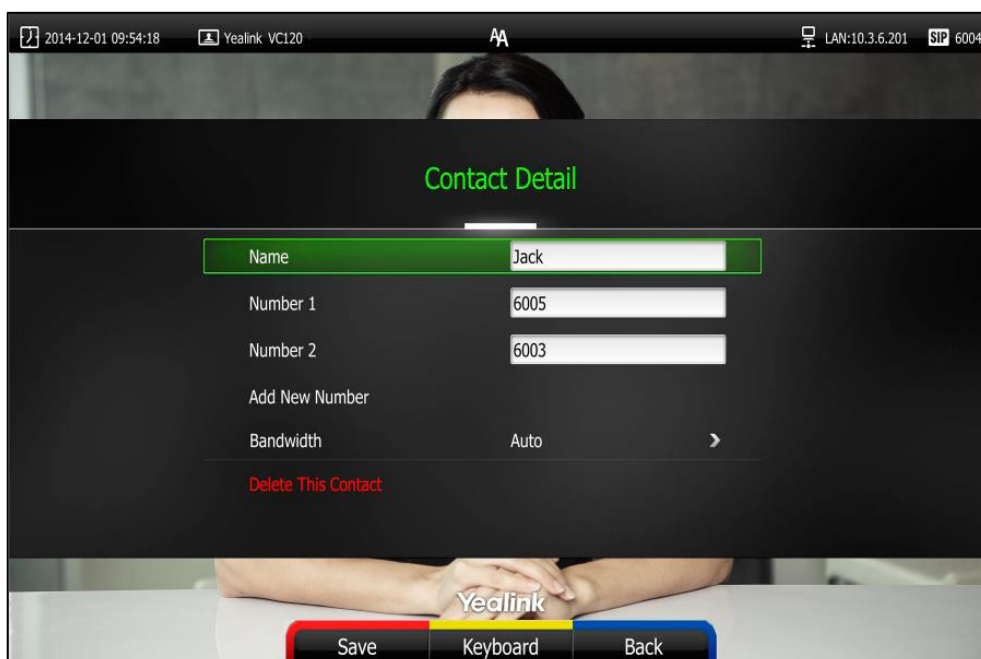
You can select **Add New Number** to add new numbers for the contact.













6. Press  (**Save** soft key) to accept the change or press  (**Back** soft key) to cancel.

You can also edit contacts via web user interface at the path **Directory->Local**.

Deleting Local Contacts

You can delete local contacts via the remote control or web user interface.

To delete a local contact via the remote control:

1. Press  (**Call** soft key).
2. Press  or  to select the **Directory** menu.
3. Press  or  to select the desired local contact.
4. Press  (**Detail** soft key).
5. Press  or  to highlight the **Delete This Contact**, and then press  .
The display device prompts "Delete this contact?"
6. Press  or  to highlight **OK**.

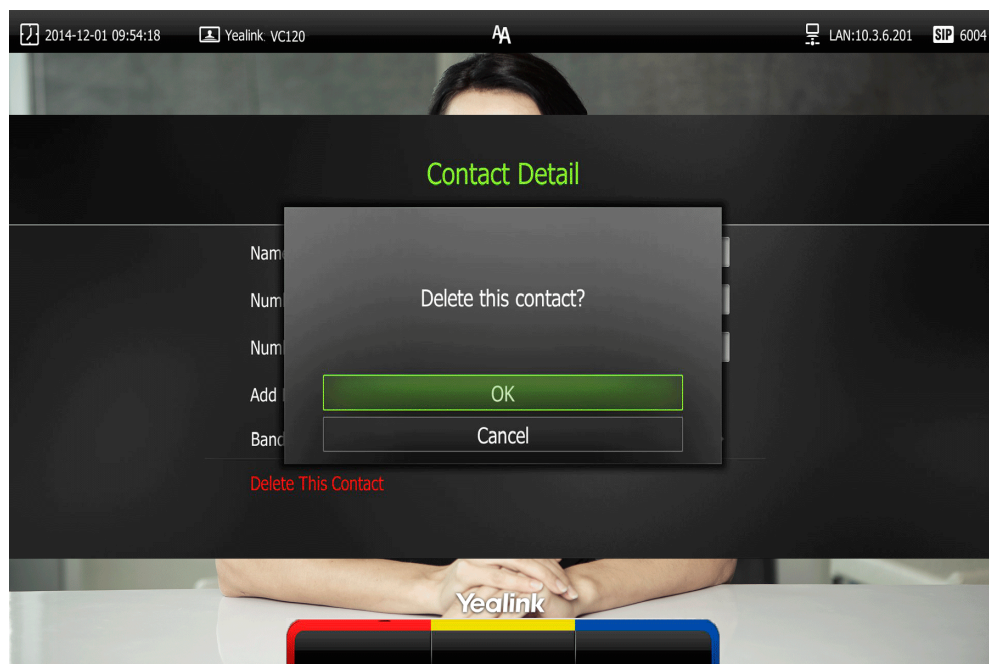

7. Press  to delete the local contact.

You can also delete contacts via web user interface at the path **Directory->Local**.

Searching for Contacts

You can search local contacts via the remote control or web user interface. If you log into the Yealink Cloud platform, you can also search for Yealink Cloud contacts.

To search for contacts via the remote control:

1. Press  (**Call** soft key).

2. Press ◀ or ▶ to select the **Directory** menu.
3. Press ▲ or ▼ to select the searching box.
You can select the desired contact type from the pull-down list of the **All Contacts** first.
4. Enter a few or all characters of the contact name or numbers.
The contacts whose names or phone numbers matches the characters entered will appear on the display device.

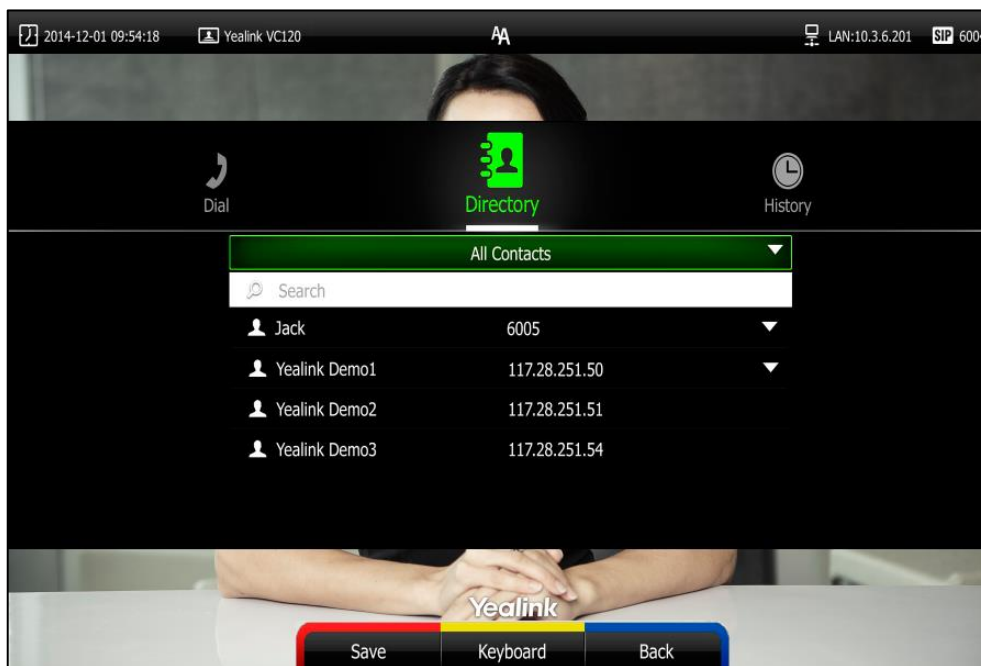

5. You can press ▲ or ▼ to select the desired contact, and then call or edit the contact.



Search Source List in Dialing



You can search for a contact from the desired lists when the phone is in the pre-dialing screen. The lists can be History, Local Directory, Cloud Contacts and LDAP.

In the pre-dialing screen, when you enter a few characters, the system will search the matched contacts from the enabled search source lists, and display the result in the dialing screen.

If you want to match the LADP list, LDAP are configured already. For more information on how to configure LDAP, contact your system administrator.

To configure search source list in dialing via web user interface:

1. Click on **Directory**->**Setting**.
2. In the **Search Source List In Dialing** block, select the desired list from the **Disabled** column and click .
The selected list appears in the **Enabled** column.
3. Repeat step 2 to add more lists to the **Enabled** column.
4. (Optional.) To remove a list from the **Enabled** column, select the desired list and then click .



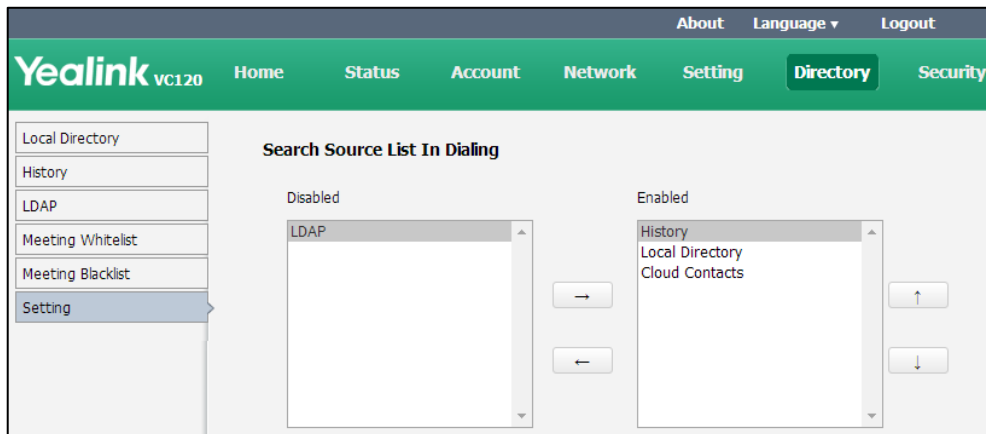

- To adjust the display order of the enabled list, select the desired list, and click  or .



- Click **Confirm** to accept the change.

Note Search source list in dialing is only configurable via web user interface.

To place a call via search source lists:

- Press  (Call soft key).
- Enter a few or all characters of the contact name or numbers.
The contacts whose names or phone numbers matches the characters entered will appear on the display device.
- Press  or  to select the desired contact, and then press  or  to call the contact.

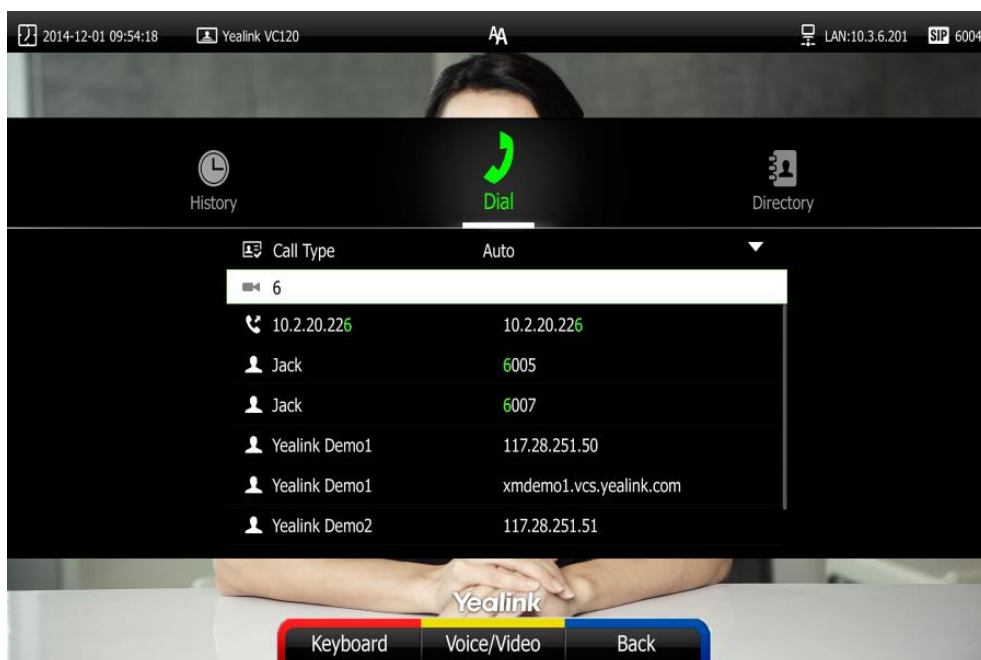

Importing/Exporting Contact Lists

You can import or export the contact list to share contacts between different systems or between system and application software (e.g., Outlook).

The VC120 video conferencing system only supports the XML and CSV format contact lists. You can only import or export the contact list via web user interface.

To import an XML file of contact lists via web user interface:

1. Click on **Directory**->**Local**.
2. Click **Import/Export**.
3. Click **Import**.
4. Click **Browse** to locate a contact list file (file format must be *.xml) from your local system.

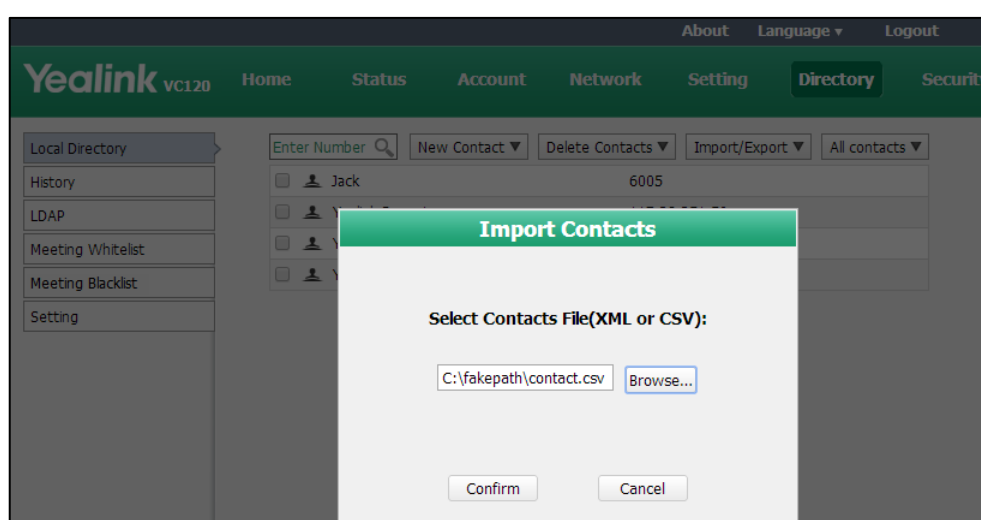

5. Click **Confirm** to import the contact list.
The web user interface prompts "The original contact will be covered, continue?".
6. Click **Confirm** to complete importing the contact list.
The web user interface prompts "Contacts imported successfully!".

To import a CSV file of contact lists via web user interface:

1. Click on **Directory**->**Local**.
2. Click **Import/Export**.
3. Click **Import**.
4. Click **Browse** to locate a contact list file (file format must be *.csv) from your local system.

5. Click **Confirm**.

The web user interface is shown as below:

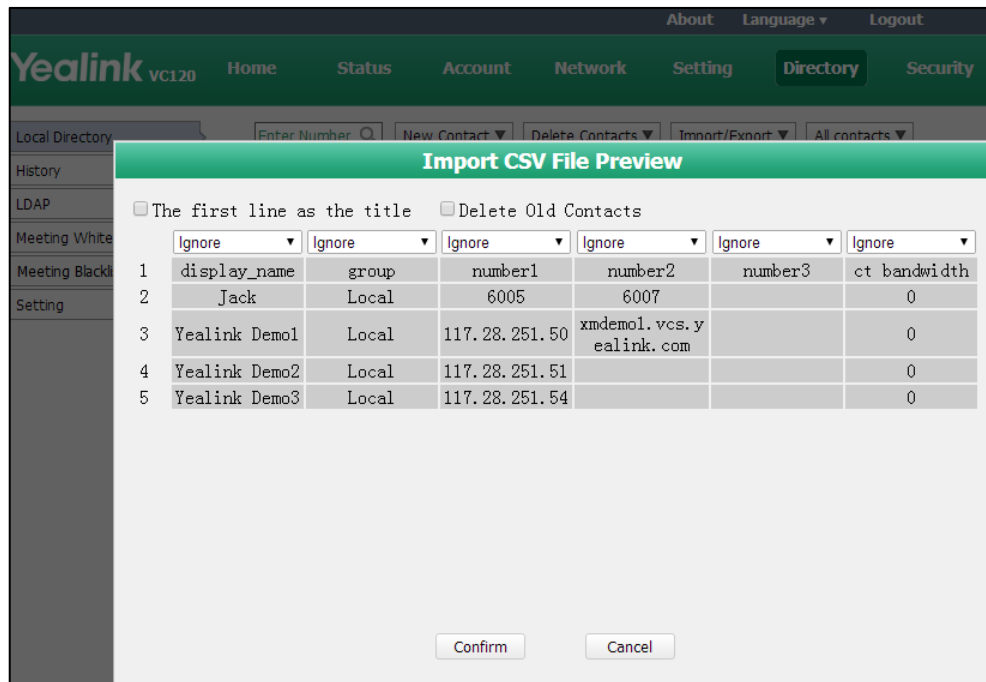

6. (Optional.) Check the **The first line as the title** checkbox.

It will prevent importing the title of the contact information which is located in the first line of the CSV file.

7. (Optional.) Check the **Delete Old Contacts** checkbox.

It will delete all existing contacts while importing the contact list.

8. Select the desired value from the pull-down list.

- If **Ignore** is selected, this column will not be imported to the system.
- If **Display Name** is selected, this column will be imported to the system as the contact's name.

- If **number1/2/3** is selected, this column will be imported to the system as the contact's number.

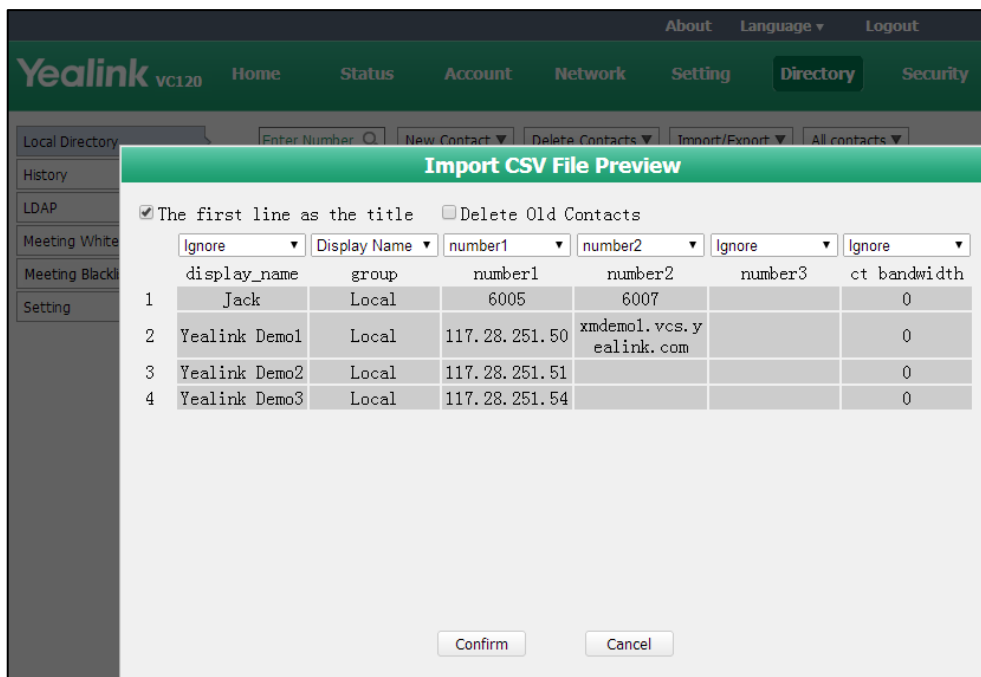

9. Click **Confirm** to complete importing the contact list.

The web user interface prompts "Contacts imported successfully!".

Note

The display name must be imported to the system. If not, the CSV file cannot be imported.

To export a contact list via web user interface:







1. Click on **Directory->Local**.
2. Click **Import/Export**.
3. Click **Export XML** or **Export CSV**.
4. The contact list is saved to your local system.

Call History Management

The VC120 video conferencing system maintains call history lists of All Calls, Missed Calls, Placed Calls and Received Calls. The system supports up to 100 history entries (local entries and Cloud entries). You can view the call history, place a call or delete an entry from the call history list.

To save call history on the system, you need to enable the history record feature in advance. The history record feature is enabled by default, and you can configure it via the remote control or web user interface.

To configure history record feature via the remote control:

1. Press  (**Menu** soft key) to enter main menu.
2. Press  or  to select the **Call Features** menu.
3. Press  or  to scroll to **History record**, and then press  to enable or disable this feature.

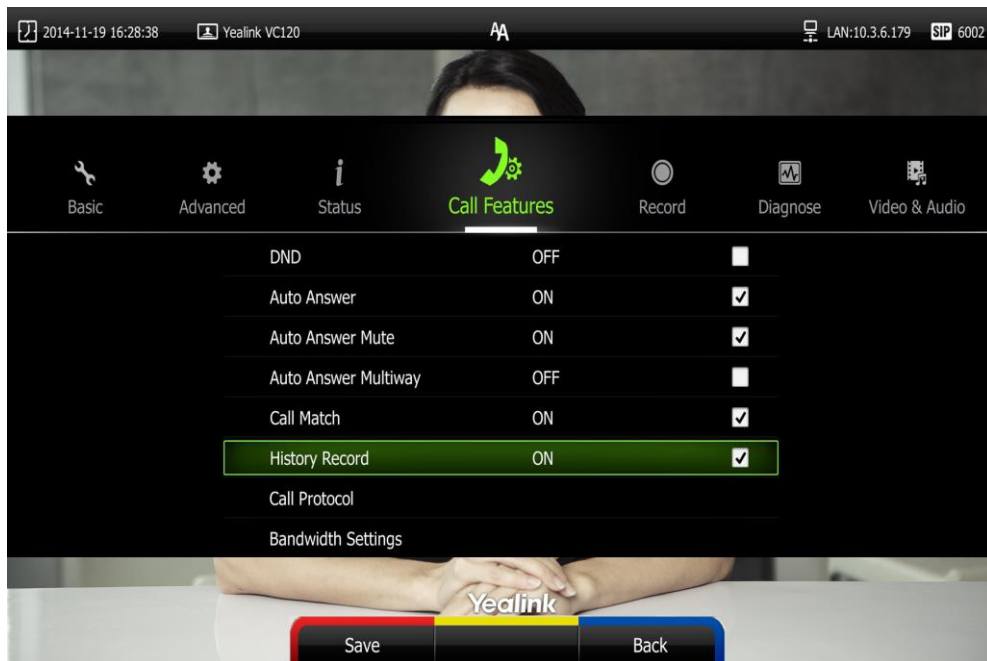









4. Press  (**Save** soft key) to accept the change.



The history record feature is configurable via web user interface at the path **Setting->Call Features->History Record**.

Viewing Call History

You can view call history via the remote control, video conferencing phone or web user interface.

To view call history via the remote control:

1. Press  (**Call** soft key).
2. Press  or  to select the **History** menu.
The display device shows recent call history.
3. Press  to expand the pull-down list of **All Calls**.
4. Press  or  to select the desired call history list, and then press .
5. Press  or  to view the desired call history.

If the call history is more than one page, you can press  or  to turn pages.

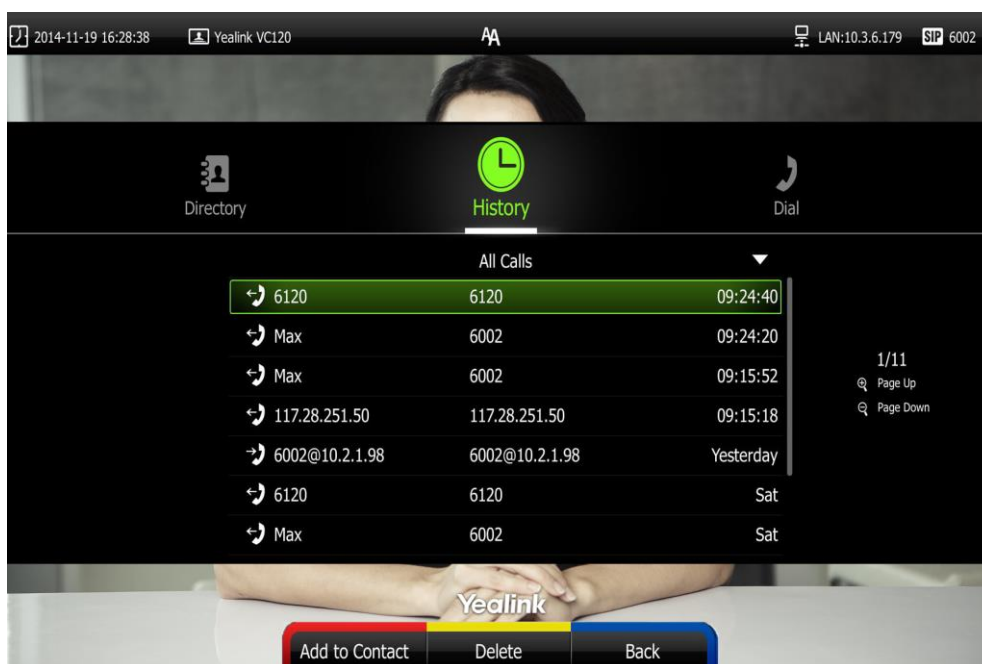





To view call history via the video conferencing phone:

1. Press the **History** soft key.

The LCD screen of video conferencing phone displays all call records.





2. Press  or  soft key to switch between **All Calls**, **Missed Calls**, **Placed Calls**, and **Received Calls** list.
3. Press  or  to view the desired call history.

Call history can be viewed via the web user interface at the path **Directory->History**.

Placing a Call from the Call History List

You can place a call from the call history list via the remote control, video conferencing phone or web user interface.

To place a call from the call history list via the remote control:

1. Press  (**Call** soft key).
2. Press  or  to select the **History** menu.
The display device shows recent call history.
3. Select the desired call history list from the pull-down list of **All Calls**, and then press



4. Press ▲ or ▼ to select the desired call history.

If the call history is more than one page, you can press ⊕ or ⊖ to turn pages.

5. Press or .

To place a call from the call history list via the video conferencing phone:

1. Press the **History** soft key.

The video conferencing phone's LCD screen displays all call records.





2. Press ◀ or ▶ soft key to switch between **All Calls**, **Missed Calls**, **Placed Calls**, and **Received Calls** list.
3. Press ▲ or ▼ to select the desired call history.
4. Press the **Send** soft key, or .

Deleting an Entry from the Call History List

You can delete an entry from the call history list via the remote control or web user interface.

To delete an entry from the call history list via the remote control:

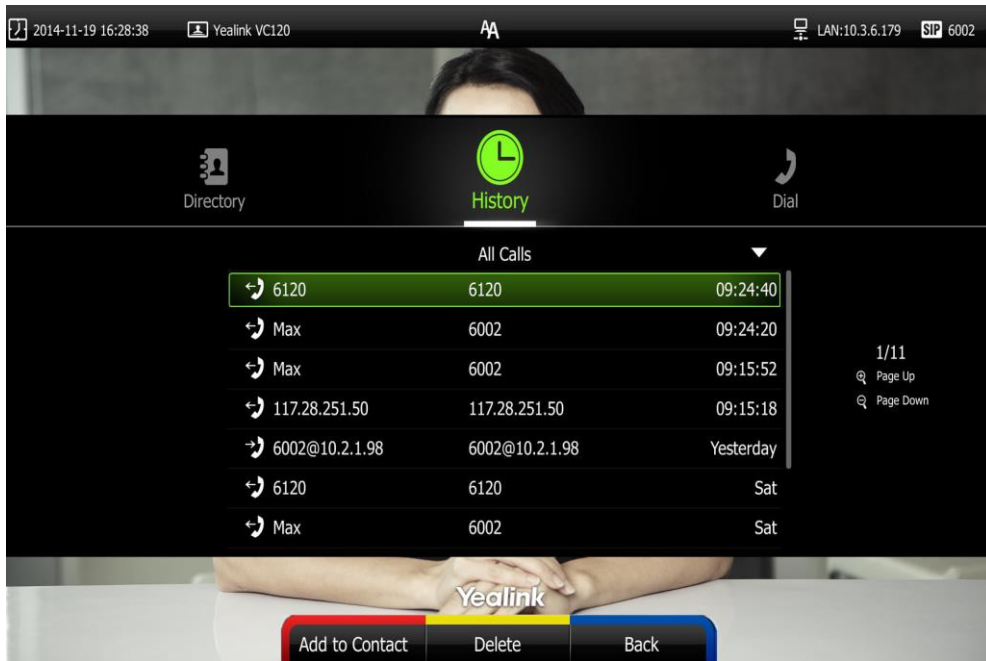

1. Press (**Call** soft key).
2. Press ◀ or ▶ to select the **History** menu.
The display device shows recent call history.
3. Press ▲ or ▼ to select the desired call history.

If the call history is more than one page, you can press  or  to turn pages.



4. Press  (**Delete** soft key) to delete the entry.

To clear call history via the remote control:

1. Press  (**Call** soft key).
2. Press  or  to select the **History** menu.
The display device shows recent call history.

3. Press  (**Clear** soft key).

You can also select the call history list you want to clear from the pull-down list of **All Calls**, and then press  (**Clear** soft key) to clear the call history in the selected list.

The display device prompt “Delete all records?”.

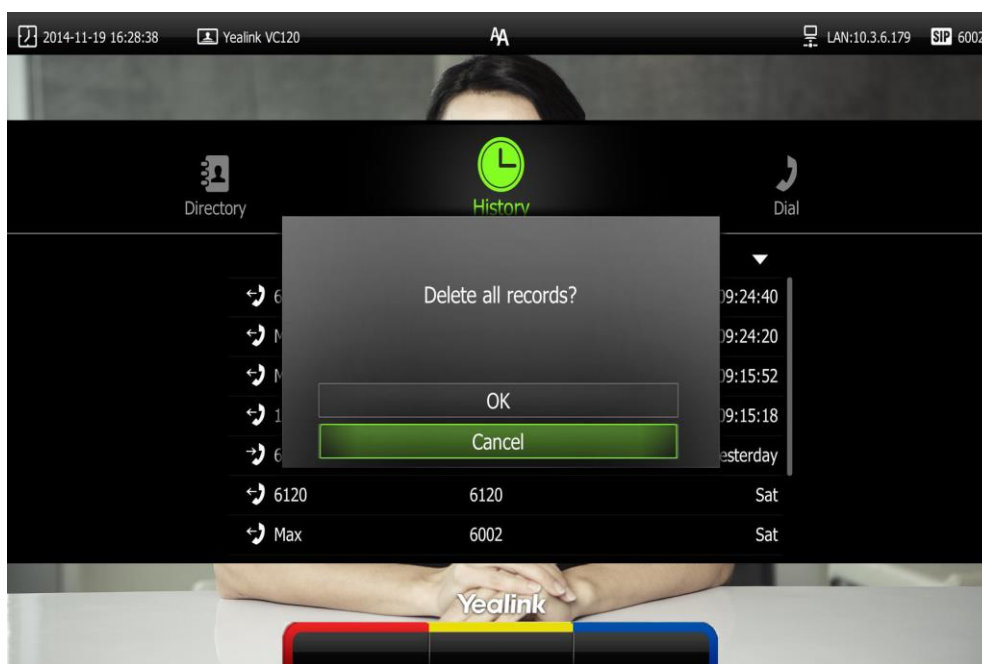



5. Press ▲ or ▼ to select **OK**.
6. Press  to clear the call history.



Adding a Local Contact from the Call History List

To add a local contact from the call history list via the remote control:

1. Press  (**Call** soft key).
2. Press ◀ or ▶ to select the **History** menu.
The display device shows recent call history.
3. Press ▲ or ▼ to select the desired call history.

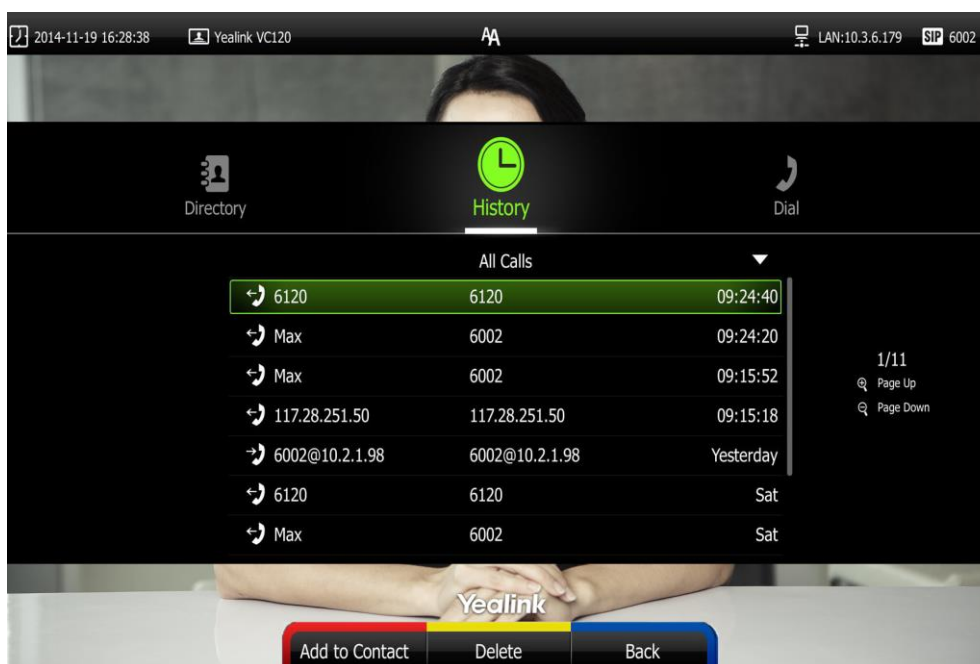
If the call history is more than one page, you can press  or  to turn pages.



4. Press  (**Add to Contact** soft key).
5. Enter contact name in the **Name** field.
6. Press  (**Save** soft key) to save the contact.

You can add more than one number for the contact. For more information, refer to [Adding Local Contacts](#) on page 72.

Call history management feature is configurable via web user interface at the path **Directory->History**.



Call Protocol

The VC120 video conferencing system supports SIP and H.323 call protocols. H.323 is commonly used to communicate to other video conferencing systems. SIP is commonly used to communicate with other VoIP devices. You can configure which protocol is to be used when the system is making calls. When the **Auto** call protocol is used, the system preferentially uses the H.323 protocol to place calls. If there is no available H.323 account on the system, the system will switch to the SIP protocol. You can also specify the desired protocol for the system to place calls via the remote control or web user interface.

Note

Before configuring call protocol, ensure the remote system supports the call protocol too. For more information, contact your system administrator.

To configure the call protocol via the remote control:

1. Press  (**Menu** soft key) to enter main menu.
2. Press  or  to select the **Call Features** menu.

3. Press ▲ or ▼ to scroll to **Call Protocol**, and then press **OK**.

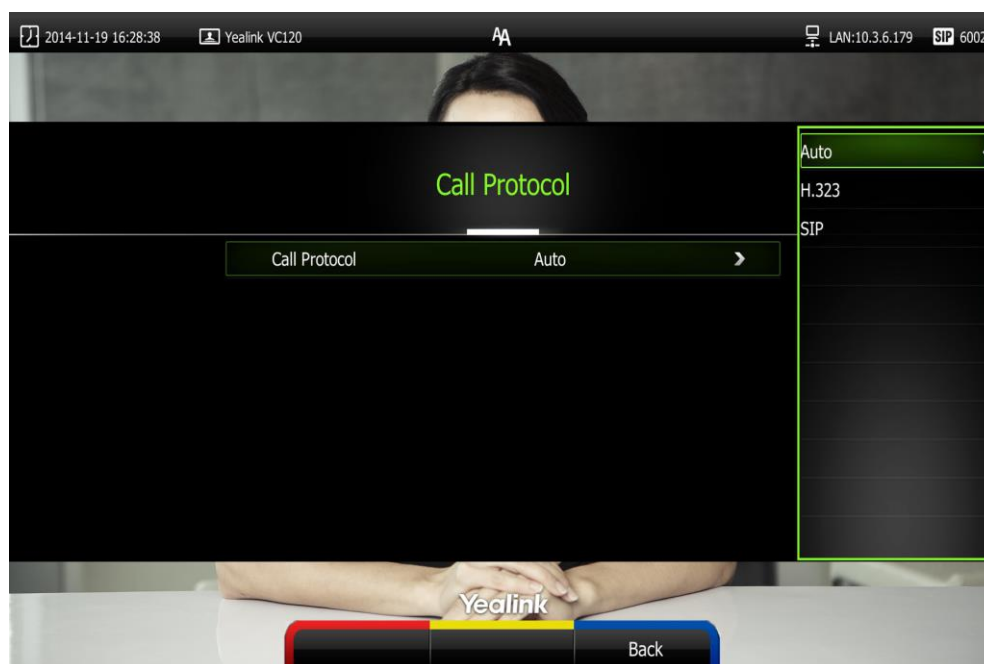

4. Select desired type or **Auto** from the pull-down list of **Call Protocol**.
5. Press  (**Save** soft key) to accept the change.

Call protocol is configurable via web user interface at the path **Setting->Call Features->Call Protocol**.

Bandwidth Settings

By default, the system automatically detects the available bandwidth and uses this connection speed. The VC120 supports connecting to other devices with different bandwidth. If a device with lower bandwidth joins a call, the video quality will stay the same or will not reduce a lot. You can specify the uplink and downlink bandwidths for the system to achieve the best result. The uplink bandwidth refers to the max bandwidth of outgoing calls. The downlink bandwidth refers to the max bandwidth of incoming calls.







Available bandwidths for the system are: Auto, 256kb/s, 384kb/s, 512 kb/s, 640 kb/s, 768 kb/s, 1024kb/s, 1280kb/s, 1500kb/s, 2000kb/s, 3000kb/s, 4000kb/s, 5000kb/s, 6000kb/s. You can configure which bandwidth is to be used when in the dialing screen. The optional maximum bandwidth in dialing screen is the uplink bandwidth. For more information, refer to [Placing a Call Using the Remote Control](#) on page 97.

You can configure the uplink and downlink bandwidth of the system via the remote control or web user interface.

Note

The actual bandwidth depends on the performance of the remote system, and is affected by the quality of the communication channel.

To configure the uplink and downlink bandwidth via the remote control:

1. Press  (**Menu** soft key) to enter main menu.
2. Press  or  to select the **Call Features** menu.
3. Press  or  to scroll to **Bandwidth Settings**, and then press .
4. Select desired bandwidth from the pull-down list of **Uplink Bandwidth**.
If **Auto** is selected, the system will select the appropriate bandwidth automatically.
5. Select desired bandwidth from the pull-down list of **Downlink Bandwidth**.
If **Auto** is selected, the system will select the appropriate bandwidth automatically.

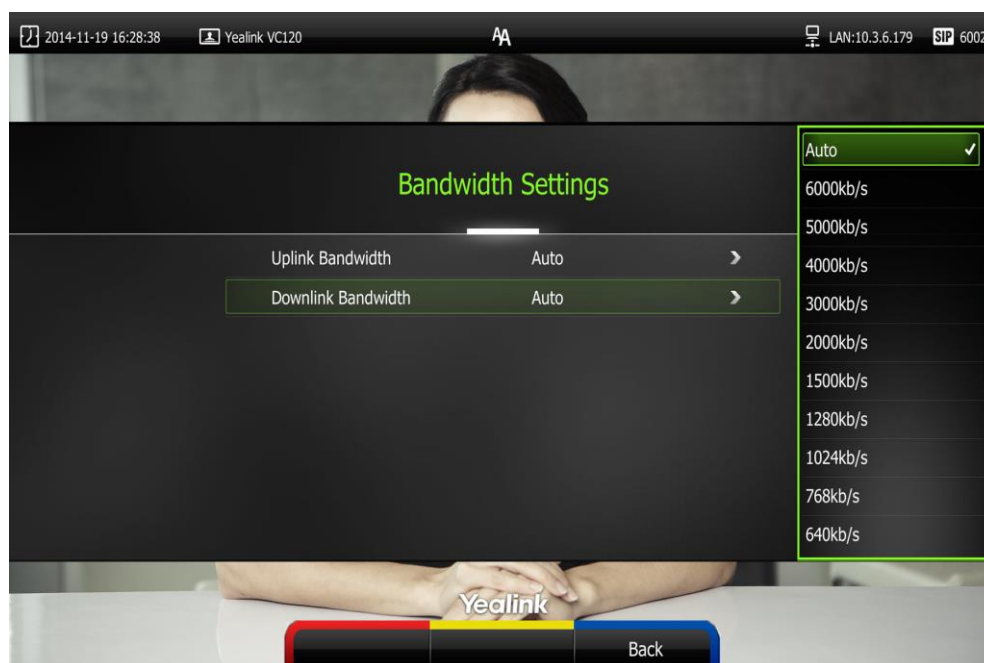

6. Press  (**Save** soft key) to accept the change.

Note

The priority of bandwidth is as follows:
System bandwidth > Contact bandwidth (refer to [Adding Local Contacts](#)).

For example: the system bandwidth is 512kbps, if contact bandwidth is set to a value greater than 512bps, then the actual contact bandwidth will be 512bps. If contact bandwidth is set to a value less than 512bps, then the actual contact bandwidth will be the value set by user.

Bandwidth is configurable via web user interface at the path **Setting->Call Features-> Uplink Bandwidth/Downlink Bandwidth**.

Audio Settings

Audio Output Device







The system supports the following audio output devices:

- **Auto** (audio output device with the highest priority is selected automatically)
- **VCS Phone** (video conferencing phone)
- **HDMI** (built-in speakerphone of the display device)
- **Line Output** (speakerphone connected to the Line Out port of the VC120 codec)

By default, the system automatically selects the audio output devices with the highest priority. The priority is: VCS Phone> HDMI>Line Output. If the audio output device with the highest priority is removed from the VC120, the VC120 will select the next highest priority device.

You can also specify the desired audio output device via the remote control or the web user interface.

To configure the audio output device via the remote control:

1. Press  (**Menu** soft key) to enter main menu.
2. Press  or  to select the **Video & Audio** menu.
3. Press  or  to scroll to **Audio Settings**, and then press .
4. Select desired audio output device from the pull-down list of **Audio Output**.

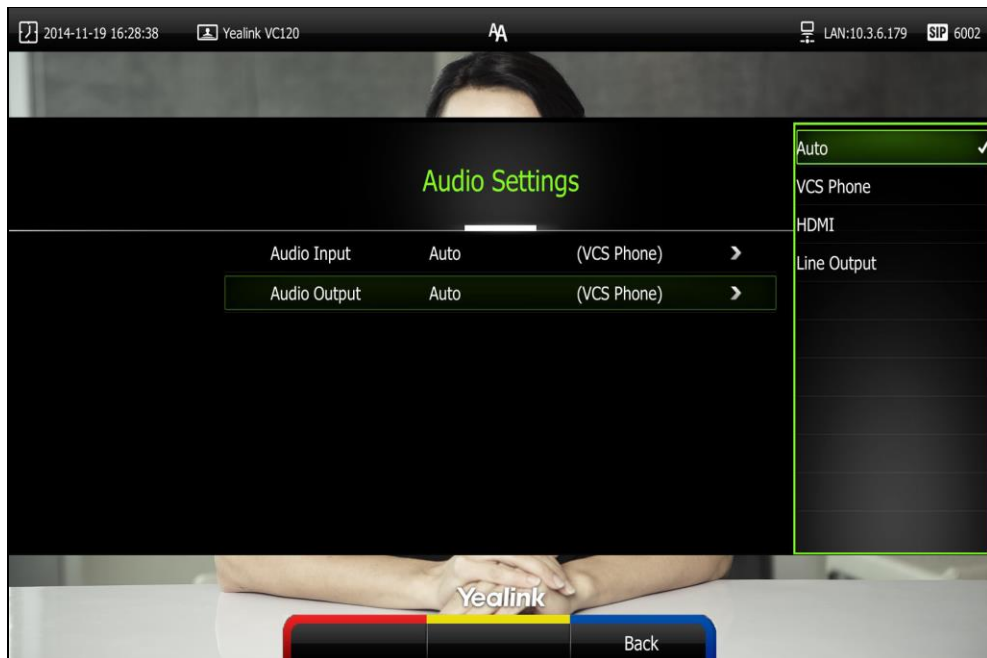

5. Press  (**Save** soft key) to accept the change.

Audio output device is configurable via web user interface at the path **Setting->Video & Audio->Audio Output**.

Audio Input Device

The system supports the following audio input devices:

- **Auto** (select the audio input device with the highest priority)
- **VCS Phone** (video conferencing phone)
- **Wired Micpod** (VCM30)
- **Line Input** (microphone connected to the Line In port on the VC120 codec)
- **Line In + VCS Phone**
- **Line In + Wired Micpod**
- **Line In + Wireless Micpod**

The priority of audio input device is:

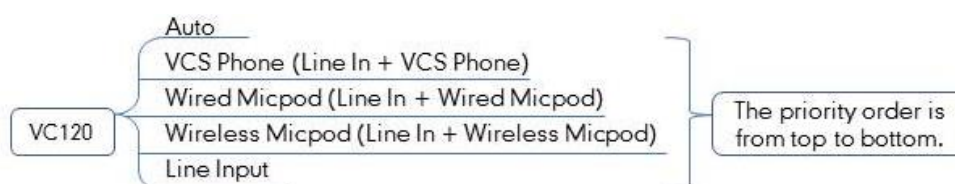



Note

For more information on the wireless micpod, please contact Yealink agents.

By default, the VC120 automatically selects the audio input devices with the highest priority. If you select "Line In + device" option, the VC120 will use microphone connected to the Line In port and the corresponding device to pick up audio at the same time.

You can also specify the desired audio input device via the remote control or the web user interface.

To configure the audio input device via the remote control:

1. Press  (**Menu** soft key) to enter main menu.
2. Press ◀ or ▶ to select the **Video & Audio** menu.
3. Press ▲ or ▼ to scroll to **Audio Setting**, and then press .
4. Select desired audio input device from the pull-down list of **Audio Input**.
 - If **VCS Phone** is selected as the audio output device manually or automatically, the audio input device must be **VCS Phone** or **Line Input +VCS Phone**.
 - If **Line Input** is selected as the audio input device, the near-end audio output device will not play sound from the Line Input device.
 - If "Line In + device" is selected as the audio input device, the near-end audio output device will play sound from the Line Input device.

During a video training for main office and branch office, both offices need to hear the video sound, you can select this option.

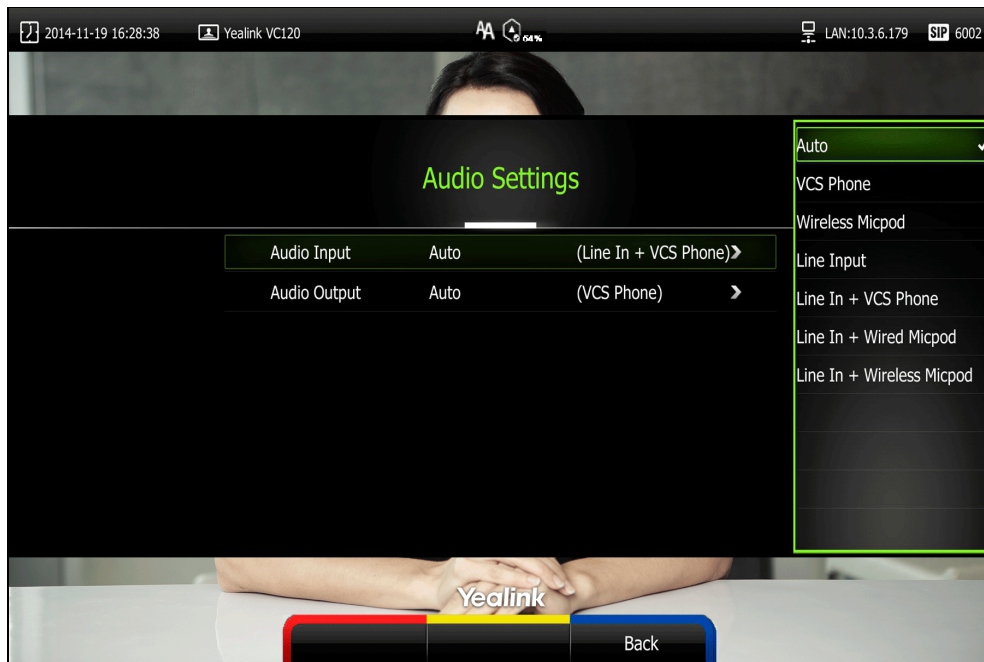

6. Press  (Save soft key) to accept the change.

Audio input device is configurable via web user interface at the path **Setting->Video & Audio->Audio Input**.

Far-end Camera Control

Local video is displayed on the display device of the far site during a call. For the best view, you can enable the **Far Control of Camera** feature to allow the far site to control the focus and angle of the local camera. You can also specify whether the far site is allowed to store and use the local camera presets.

You can configure the far-end camera control feature via the remote control or web user interface.

Far-end camera control features you need to know:

Parameters	Description
Far Control of Camera	Enables or disables the far-end to control the local camera.
Far Set of Camera Presets	Enables or disables the far-end to store the local camera presets.
Far Move to Camera Presets	Enables or disables the far-end to use the local camera presets.

To configure Far-end Camera Control via the remote control:

1. Press  (Menu soft key) to enter main menu.

2. Press ◀ or ▶ to select the **Video & Audio** menu.
3. Press ▲ or ▼ to scroll to **Far-end Camera Control**, and then press **OK**.
4. Press ▲ or ▼ to scroll to **Far Control of Camera**, and then press **OK** to enable or disable this feature.
5. Press ▲ or ▼ to scroll to **Far Set of Camera Presets**, and then press **OK** to enable or disable this feature.

If you enable this feature, and the remote system completes adjusting local camera, it can save the presets of the local camera.

6. Press ▲ or ▼ to scroll to **Far Move to Camera Presets**, and then press **OK**.

If you enable this feature, the remote system can use the saved presets of the local camera during a call.

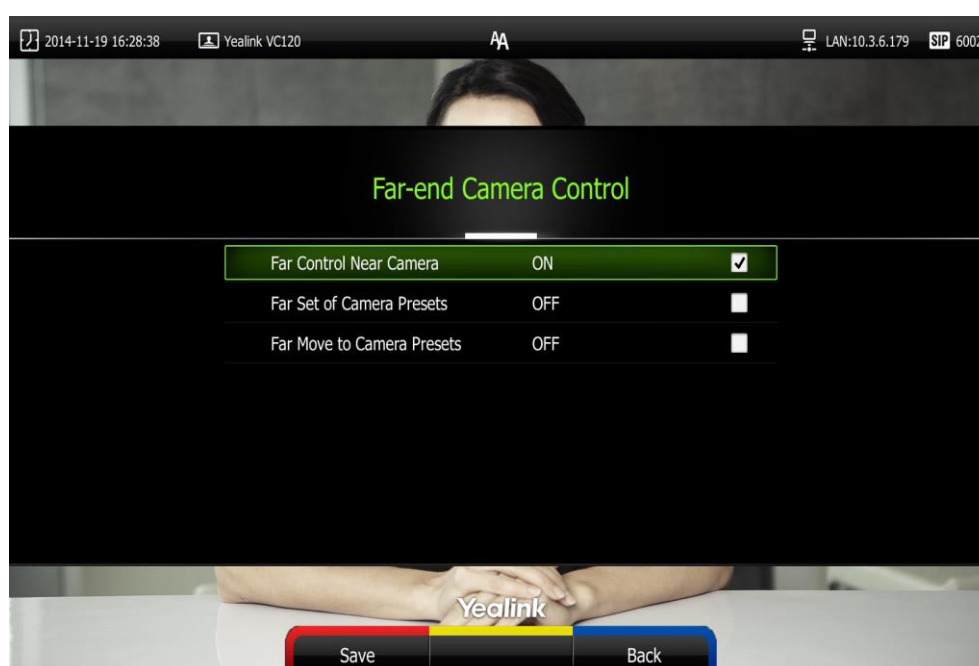

7. Press  (Save soft key) to accept the change.

Far-end Camera Control is configurable via web user interface at the path **Setting->Video & Audio-> Far Control Near Camera/ Far Set of Camera Presets/ Far Move to Camera Presets**.

Using the VC120 Video Conferencing System

The VC120 video conferencing system can be used to place calls, answer calls, or conduct a conference call. You can switch layout, record videos or capture screenshots during a call.

This chapter provides basic operating instructions for the VC120 video conferencing system. Topics include:

- [Account Polling](#)
- [Placing Calls](#)
- [Answering or Rejecting Calls](#)
- [Ending Calls](#)
- [Call Management](#)

If you require additional information or assistance with your new phone, contact your system administrator.

Account Polling

When you dial account numbers of other system, account polling feature enables your system to use different call types according to this priority: Cloud platform>H.323 account>SIP account. If you cannot call other systems using all your registered accounts, then this call fails.

Account polling is disabled by default. When you register multiple accounts (greater than or equal to 2) for your system, you can enable account polling feature. You can configure account polling feature via web user interface only.

The following example shows the way calls are placed when account polling is enabled or disabled

Scenario:

1. System A is registered with a Yealink Cloud account and a SIP account.

On system A, select **Auto** from the pull-down list of **Call Type** before calling.

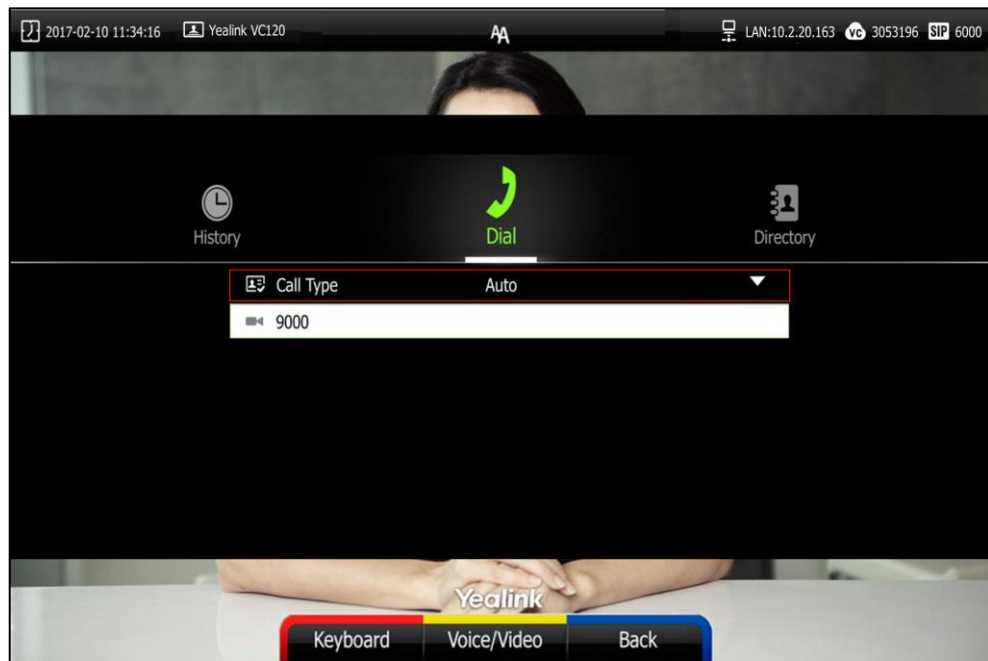

2. On system A, dial the account numbers of system B.

Result:

- If account polling is disabled, system A can only use its Yealink Cloud account (highest priority) to call system B.
- If account polling is enabled, system A will use its Yealink Cloud account (highest priority) to call system B first. If this call fails, system A continues to use its SIP account (next priority) to call system B.

To configure account polling via web user interface:

1. Click on **Setting->Call Features**.
2. Select the desired value from the pull-down list of **Account Polling**.
 - If you select **Disabled**, the system can only call other systems using the call type with the highest priority.

- If you select **Enabled**, the system will attempt to call other system using different call types according the priority.

The screenshot shows the Yealink VC120 web interface. The top navigation bar includes 'About', 'Language', and 'Logout'. Below this is a green header with 'Yealink VC120' and a menu with 'Home', 'Status', 'Account', 'Network', 'Setting' (highlighted), 'Directory', and 'Security'. On the left is a sidebar menu with categories like 'General', 'Date & Time', 'Call Features' (highlighted), 'Video & Audio', 'Camera', 'Configuration', 'Upgrade', 'Tones', 'Wireless Micpod', and '3rd-Party VMR'. The main content area displays various settings with dropdown menus and input fields. The 'Account Polling' setting at the bottom is highlighted with a red rectangular box.

Auto Answer Mute	Enabled
Auto Answer Multiway	Disabled
Auto Dialout Mute	Disabled
Call Match	Enabled
History Record	Enabled
Call Protocol	Auto
Uplink Bandwidth	Auto
Downlink Bandwidth	Auto
Abnormal Call Answering	IP Call Answer
Safe Mode Call	Enabled
Ringback Timeout(30-240)	200
Auto Refuse Timeout(30-240)	120
SIP IP Call by Proxy	Off
Default Layout of Single Screen	Remote Full screen
Network Address Adapter	Enabled
Account Polling	Disabled

3. Click **Confirm** to accept the change.

Placing Calls

You can place a call in three ways using your VC120 video conferencing system:

- Using the remote control
- Using the video conferencing phone
- Via web user interface

The VC120 video conferencing system supports two call modes:

- Voice Call
- Video Call

Note

The system supports placing calls using contact numbers, SIP URI, IP address, H. 323 account or extension. SIP URI and IP addresses can be up to 32 characters. For example: SIP URI:2210@sip.com, IP: 192.168.1.15.
For more information, contact your system administrator.

You can search and dial a contact from the call history or local directory. For more information, refer to [Directory](#) on page 71 and [Call History Management](#) on page 80.

If the system fails to call, you can troubleshoot the problems according to the following prompts:



Prompts	Description
Call Failed Busy Here	<ul style="list-style-type: none"> Remote system rejects your SIP call. Remote system does not answer your SIP call. Remote system has reached maximum sessions when you place a SIP call.
Call Failed Remote endpoint refused call	<ul style="list-style-type: none"> Remote system rejects your H.323 call Remote system does not answer your H.323 call. Remote system has reached maximum sessions when you place an H.323 call.
Network disconnected	Local network is disconnected.
Call Failed Request Time Out	<ul style="list-style-type: none"> Remote system network anomaly Remote system is powered off.
Maximum number of sessions reached	Local system has reached maximum sessions.

During a video call, the call duration and video of remote system are displayed on the display device.



Placing a Call Using the Remote Control

To place a call using the remote control:

1. Press  (Call soft key),  or any numeric key to enter the dialing screen.
2. Select the desired account type from the pull-down list of **Call Type** before calling.

If you select **Auto**, the system will select the desired account type according to this priority: Cloud platform> H.323 account>SIP account>H.323 IP Call>SIP IP Call. For example: a number is added to your local directory and Cloud directory at the same time, when you dial this number, the system will use Yealink Cloud platform to establish the call.

For more information, refer to [Account Polling](#) on page 93.

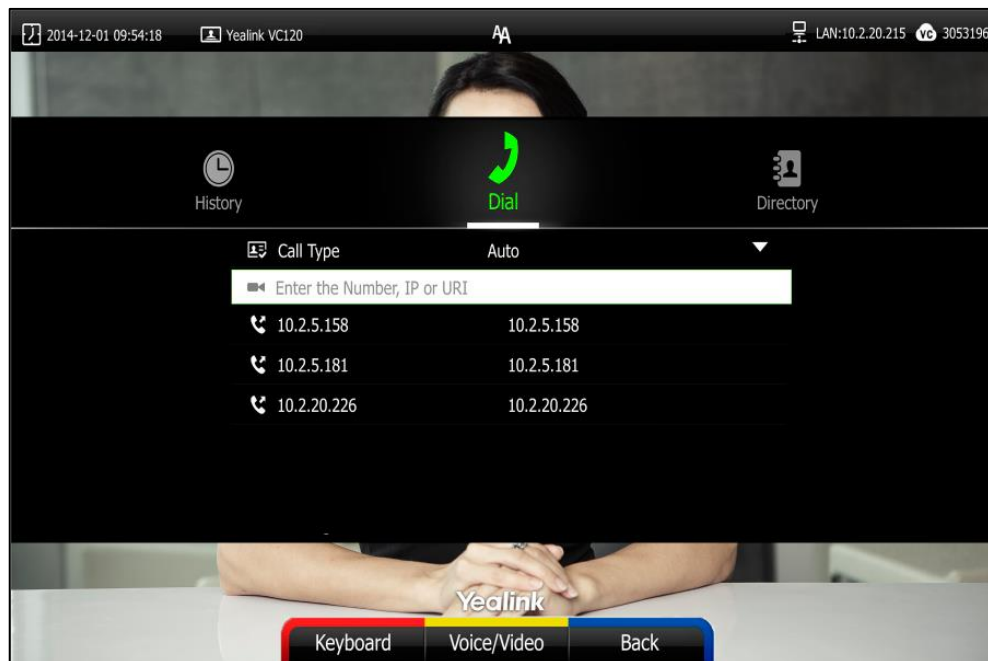

3. Enter the desired number using the keypad or the on-screen keyboard.
You can also select the desired record from the recent call history.
4. Press  (Voice/Video soft key) to switch call mode.



5. Press  or .

Placing a Call Using the Video Conferencing Phone

To place a call using the video conferencing phone:

1. Enter the desired number using the keypad.
2. Press ,  or the **Send** soft key.

Placing a Call via Web User Interface

To place a call via web user interface:





1. Log into the web user interface.
2. Click **Home**.
3. Enter the desired number in the **Enter Number** field.
4. (Optional.) Select the desired call type from the pull-down list of **Auto**.
5. (Optional.) Select the desired bandwidth from the pull-down list of **Auto**.
6. Click **Video Call** or **Voice Call**.

Placing Multiple Calls

The basic version of VC120 video conferencing system supports up to 2-way video calls and an additional voice call (an original caller and two other sites). You can import an 8-way conference license to extend the VC120 to support 8-way video calls and an additional voice call (an original caller and eight other sites). For more information on how to import an 8-way conference license, refer to [8-Way Conference License](#) on page 130.

You can use the remote control, video conferencing phone or web user interface to place multiple calls.

To place multiple calls via the remote control:



1. Place a call to the first party.
2. When the first party answers the call, press  (**More** soft key) to open **More** screen.
3. Press ▲ or ▼ to scroll to **New Call**, and then press  to place a new call.
4. Enter the number of the second party, and then press  or . When the second party answers the call, you have created a three-way conference.
5. Repeat the steps 2 to 4 to invite more parties to join the conference.

Note

You can press  or  to enter the pre-dialing screen during a call.

If you try to invite a new party when the maximum number has been reached, the system will prompt "Maximum number of sessions reached!".

To place multiple calls via the video conferencing phone:

1. Enter the desired number using the keypad.
2. When the first party answers the call, press **New Call** soft key to place a new call.
3. Enter the number of the secondary party, and then press ,  or the **Send** soft key. When the secondary party answers the call, you have created a three-way conference.
4. Repeat the steps 2 to 3 to invite more parties to join the conference.

To place multiple calls via web user interface:

1. Log into the web user interface.
2. Click **Home**.
3. Enter the number of the first party in the **Enter Number** field, and then click **Video Call** or **Voice Call**.

When the first party answers the call, the call is established.

4. Repeat the steps 3 to invite more parties to join the conference.

Chairman-Mode Conference

When the number of participants is greater than or equal to 5 in a multi-point video conference, the conference will be a chairman-mode conference. The conference organizer will act as the conference chairman who can manage the conference.

Conference Mode

Chairman-mode conference supports Single Speaker, Multi Speaker and Free Discuss three conference modes.

Single Speaker

Conference organizer authorizes a single member to speak, and all the other members are muted.

The conference organizer authorizes a single member to speak via the remote control:

1. Press  (**Preside** soft key) during a chairman-mode conference.



2. Press ◀ or ▶ to select **Single Speaker**, and then press (OK) .

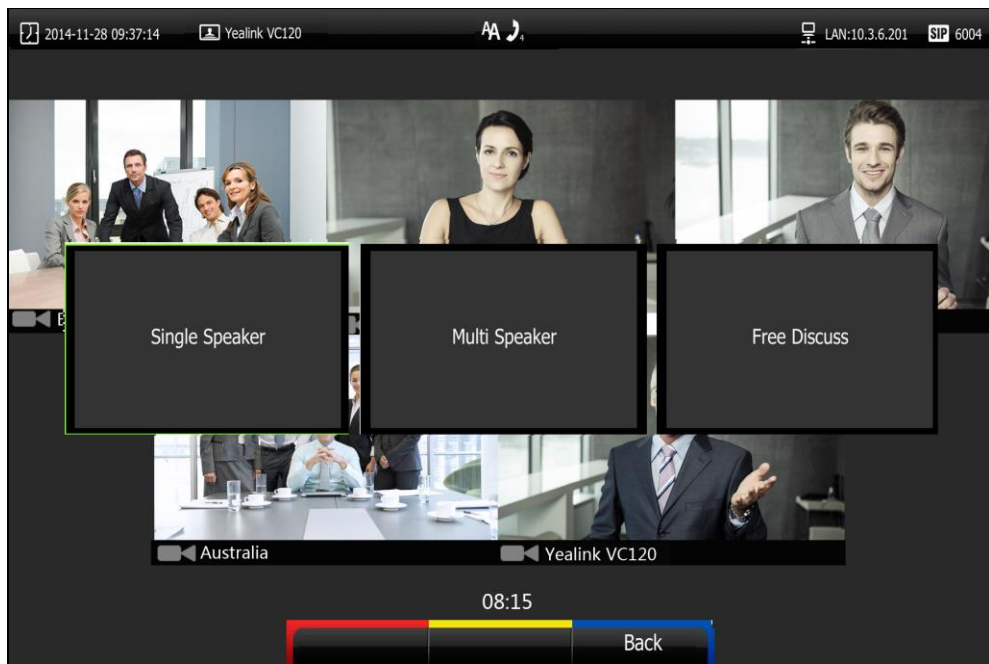

The display device shows all conference members.

3. Press the navigation key to select the desired member.
4. Do one of the following:

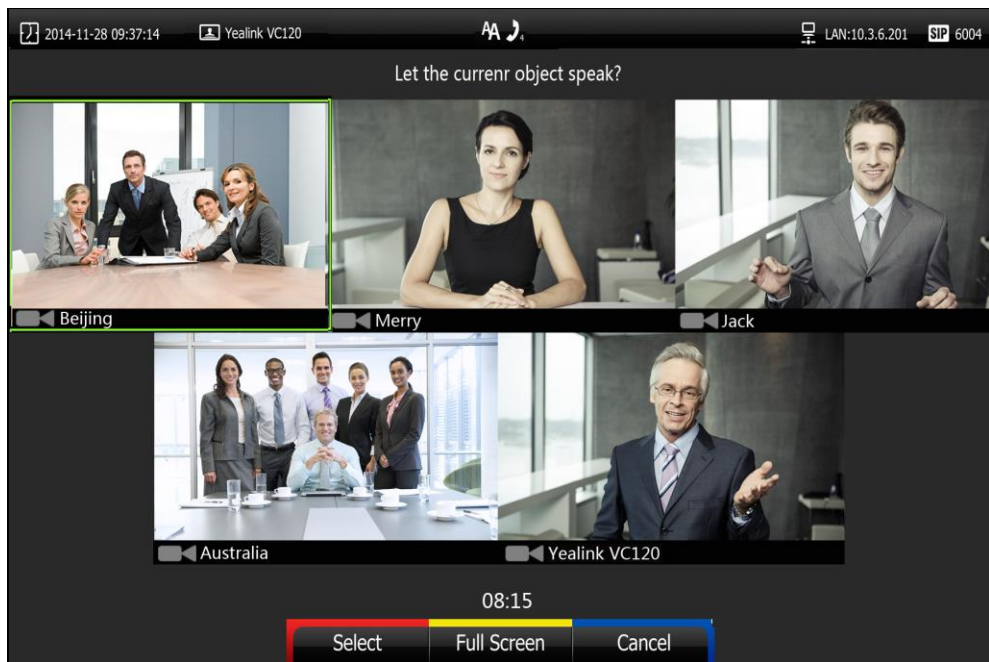

- Press (Select soft key) to authorize the member to speak.

All the other members are muted and the  mute icon appears on their video images. The authorized video image is shown in a big size format, and other video images are shown in small sizes.



- Press  (**Full Screen** soft key) to authorize the member to speak.

All the other members are muted. The authorized video image is shown in full size.



- Press  (**Cancel** soft key) to cancel.

Multi Speaker

Conference organizer authorizes multiple members to speak, and all the other members are muted.

The conference organizer authorizes multiples members to speak via the remote control:

1. Press  (**Preside** soft key) during a chairman-mode conference.



2. Press ◀ or ▶ to select **Multi Speaker**, and then press  .
The display device shows all conference members.

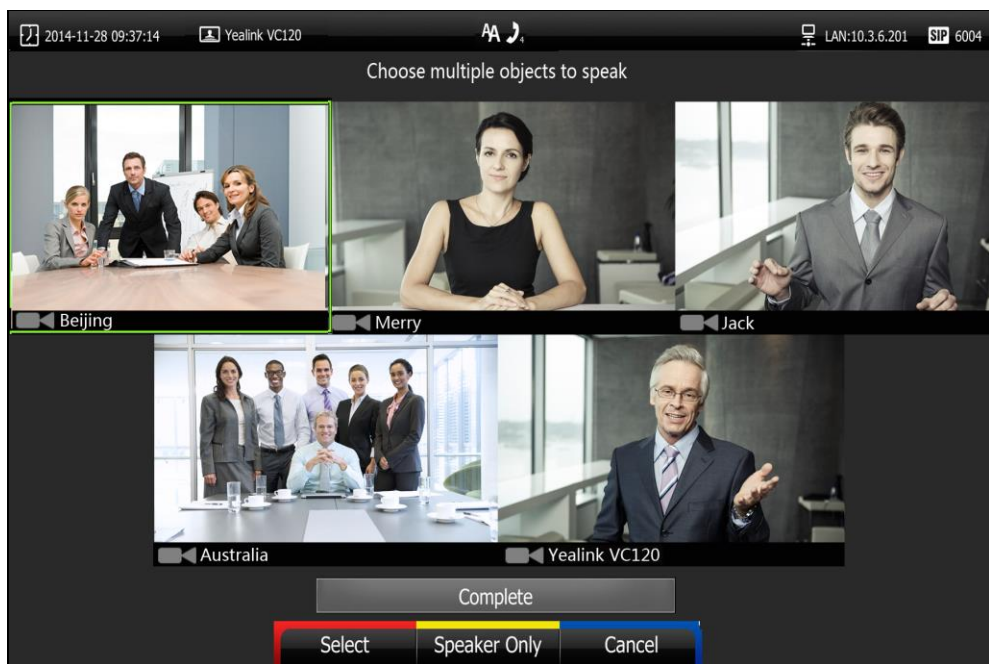

3. Press the navigation key to select the desired member, and then press  .
4. Repeat step 3 to select more members.

The  icon appears on the selected video images.



5. Do one of the following:

- Press ▲ or ▼ to scroll to **Complete**, and then press  to authorize the selected members to speak.

When two conference members are authorized, the authorized video images are shown in big sizes, and other video images are shown in small sizes.

When more than two conference members are authorized, the authorized video images are shown in same sizes.

All the other members are muted and the  mute icon appears on their video images.



- Press  (**Speaker Only** soft key) to authorize the selected members to speak. All the other members are muted. The organizer's display device only displays the authorized video images.

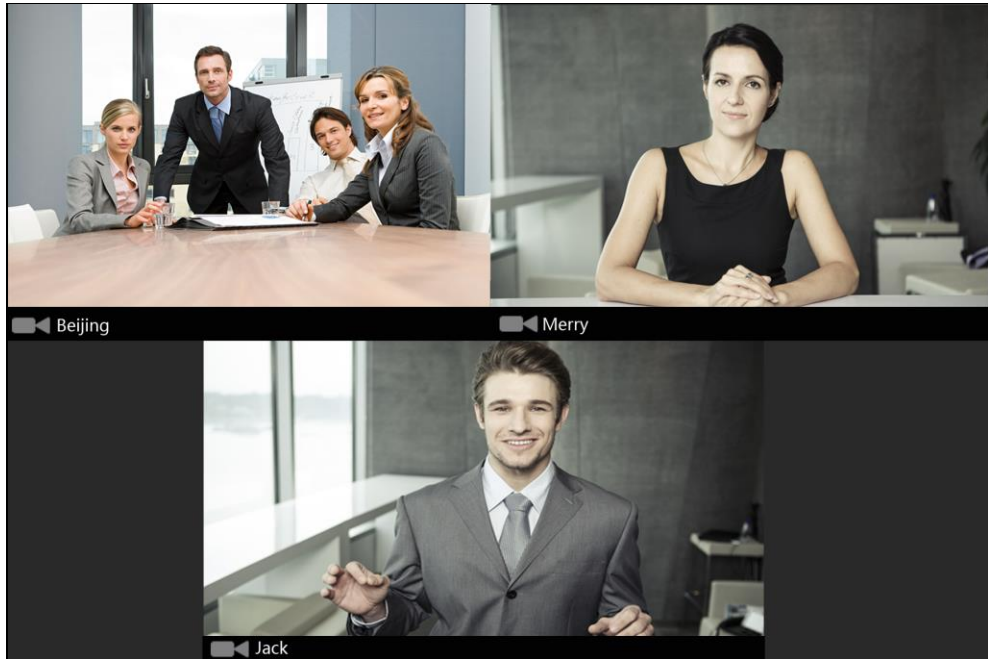

- Press  (**Cancel** soft key) to cancel.

Free Discuss

Conference organizer authorizes all conference members to speak.

The conference organizer authorizes all members to speak via the remote control:

1. Press  (**Preside** soft key) during a chairman-mode conference.

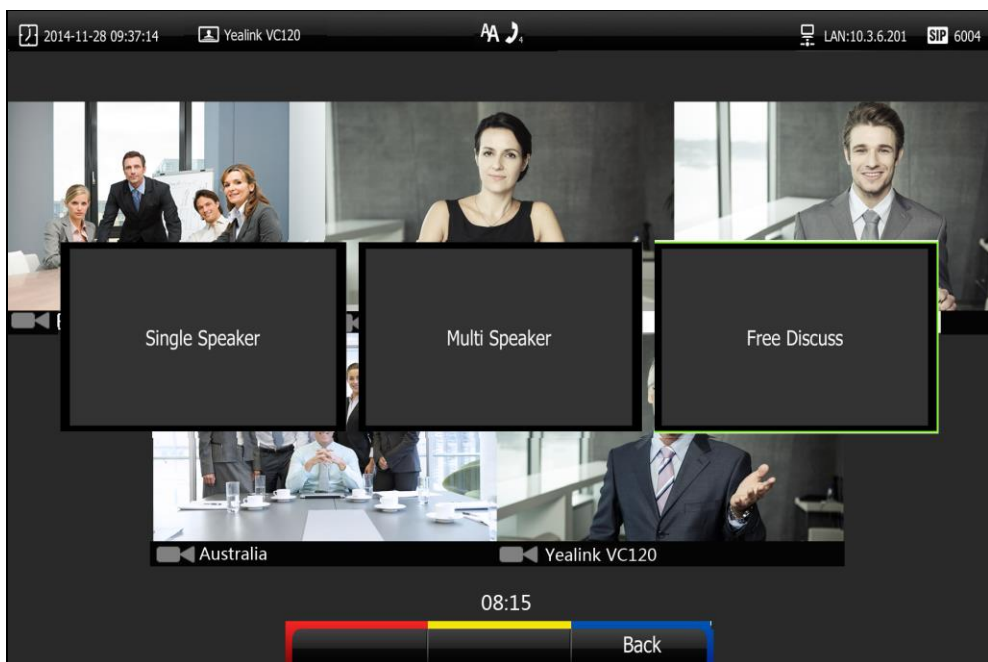

- Press ◀ or ▶ to select **Free Discuss**, and then press  .
All video images are shown in the same size.

Applying for Speaking

Only authorized conference members can speak, and other conference members are muted. Muted member can apply to the organizer for the right to speak.

The muted member applies for the right to speak via the remote control:





- Press  on the remote control or press  on the video conferencing phone or tap  on the VCM30.

The applicant's display device prompts "Request to speak" and the  icon appears on the applicant's video image.

The organizer's display device prompts "XXX Applying to speak" (XXX represents the phone number of the applicant).

- The organizer can do one of the following:



- Press ▲ or ▼ to scroll to **Allow**, and then press  to authorize the member to speak. The  mute icon disappears from the applicant's video image.
- Press ▲ or ▼ to scroll to **Reject**, and then press  to reject the request. The applicant's display device prompts "Refused to speak!" and the  icon will not disappear.
- Do nothing to ignore the request, the applicant will stay muted and the  icon will not disappear. Subsequently, the conference organizer can authorize this conference member to speak by changing conference mode.

Presentation during a Chairman-Mode Conference

During a chairman-mode conference, connect a PC to the PC port on the VC120 Codec with the supplied HDMI-VGA direct cable, the system will start a presentation automatically. The presentation will be shown in big size, and other video images will be shown in small sizes.

To display presentation in full creen via the remote control:

1. Press  (**Preside** soft key) during a chairman-mode conference.

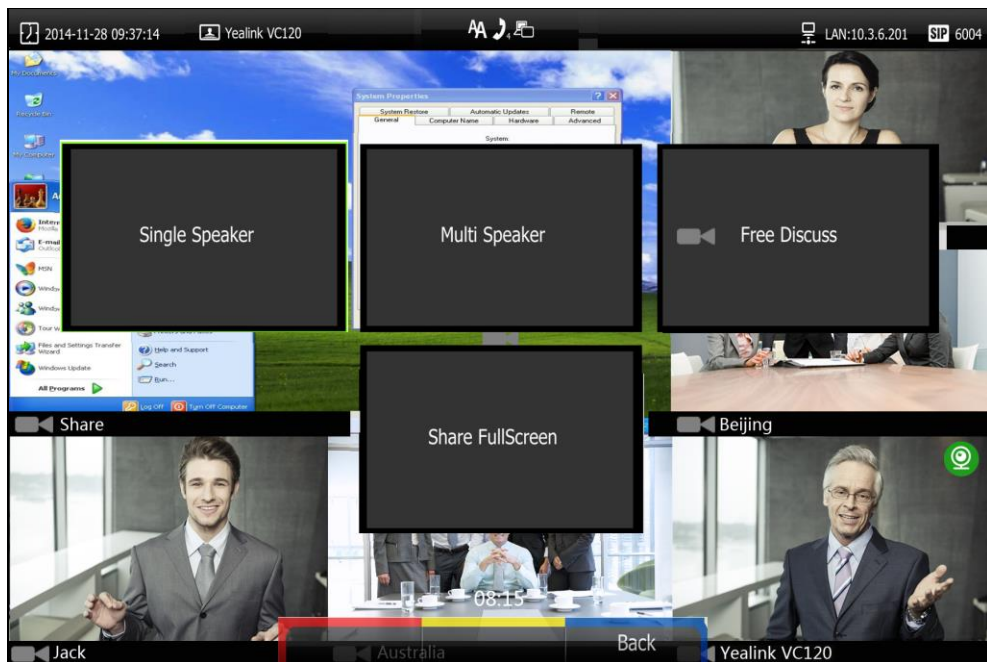



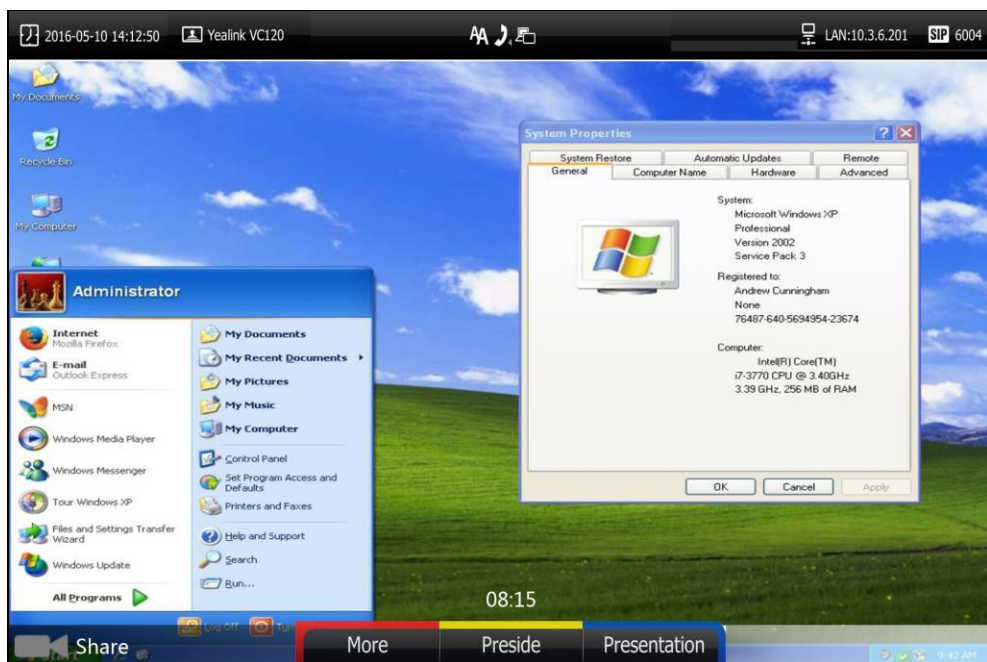

2. Press ▲ or ▼ to select **Share FullScreen**, and then press  .

The presentation is shown in full size.



To exit full screen via the remote control:

1. Press  (**Preside** soft key) during a chairman-mode conference.
2. Press  or  to select **Exit FullScreen**, and then press .

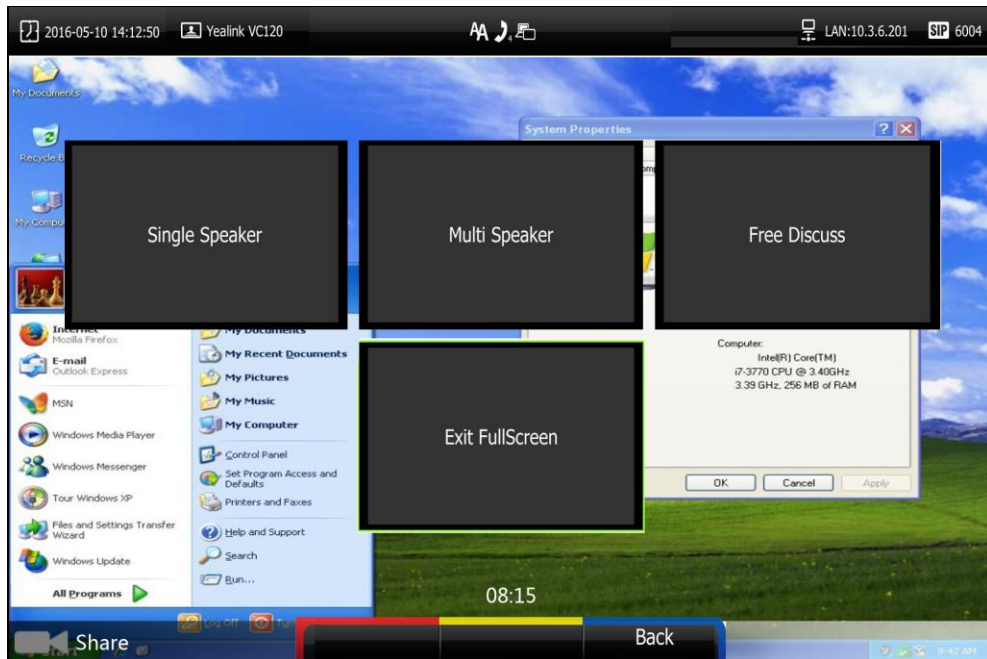

Answering or Rejecting Calls





When the system is receiving a call, you can answer or reject the call in the following ways:

- Using the remote control
- Using the video conferencing phone

If the system accepts multiple calls, a conference call will be established.



To answer a call:

Do one of the following:

- Press  or  on the remote control.
- Press ,  or the **Answer** soft key on the video conferencing phone.

To reject a call:

Do one of the following:

- Press  or select **Reject** first, and then press  on the remote control.
- Press  or the **Reject** soft key on the video conferencing phone.

Auto Answer



You can enable the auto answer feature for the system to automatically answer the first incoming call.

Auto answer features you need to know:

Parameters	Description
Auto Answer	Enables or disables the system to automatically answer the incoming call.
Auto Answer Mute	Enables or disables the system to turn off the microphone when an incoming call is answered automatically. The auto answer mute feature can be enabled only when the auto answer feature is enabled.
Auto Answer Multiway	Enables or disables the system to answer a new incoming call automatically during an active call. The auto answer multiway feature is available only when the auto answer is enabled.

Auto answer is configurable via the remote control or web user interface.

To configure auto answer via the remote control:

1. Press  (**Menu** soft key) to enter main menu.
2. Press ◀ or ▶ to select the **Call Features** menu.
3. Press ▲ or ▼ to scroll to **Auto Answer**, and then press  to enable or disable this feature.
4. Press ▲ or ▼ to scroll to **Auto Answer Mute**, and then press  to enable or disable this feature.

If you disable the auto answer feature, the system will disable the auto answer mute feature automatically.

5. Press ▲ or ▼ to scroll to **Auto Answer Multiway**, and then press **OK** to enable or disable this feature.



6. Press **Save** (Save soft key) to accept the change.

If the auto answer feature is enabled, the **AA** icon will appear on the status bar of the display device. The **AA** icon will appear on the LCD screen of the video conferencing phone.

Auto answer is configurable via web user interface at the path **Setting-> Call Features->Auto Answer/Auto Answer Mute/Auto Answer Multiway**.

Do Not Disturb (DND)

You can use DND to reject incoming calls automatically on the system. Callers will receive a busy message.

You can enable/disable DND for the system via the remote control, video conferencing phone or web user interface. You can also enable DND for the system to reject incoming call automatically during an active call.



To enable the DND mode via the remote control:

1. Press **Menu** (Menu soft key) to enter main menu.
2. Press ◀ or ▶ to select the **Call Features** menu.

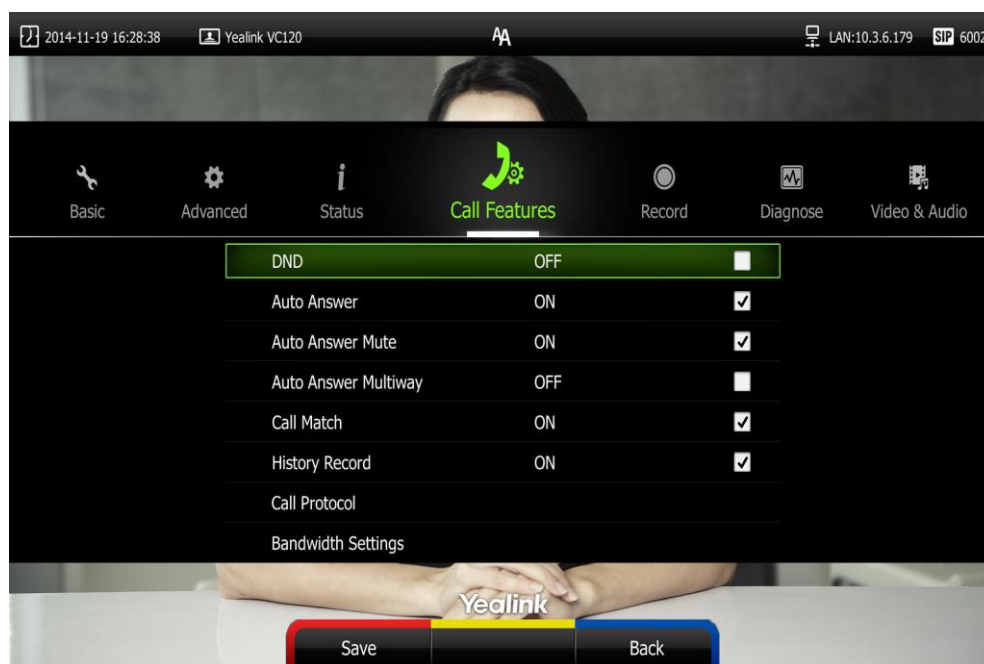
3. Press ▲ or ▼ to scroll to **DND**, and then press  to enable this feature.



4. Press  (**Save** soft key) to accept the change.

The  icon will appear on the status bar of display device, and "DND ON!" will be prompted at intervals. The  icon will appear on the LCD screen of the video conferencing phone.

The system will reject all incoming calls automatically, and the icon and numbers of missed calls are displayed on the status bar of the display device. If the system places a call, after the call is established, the DND mode will be disabled automatically.

When video conferencing phone is idle, you can also press the **DND** soft key to enable or disable this feature.



DND is configurable via web user interface at the path **Setting->Call Features->DND**.



DND during an active call

You can use the DND mode to reject incoming calls automatically during an active call.

You can enable/disable the DND mode for the system via the remote control, video conferencing phone or web user interface. The DND mode will be disabled after the call.

To enable the DND mode during an active call via the remote control:

1. Press  (**More** soft key) during an active call.
2. Press ▲ or ▼ to scroll to **DND**, and then press  to enable this feature.

The  icon will appear on the status bar of display device, the  icon will appear on the LCD screen of the video conferencing phone.

3. Press  (**Back** soft key) to return.





You can also press the **DND** soft key on the video conferencing phone to enable or disable the DND feature during an active call.





DND during an active call feature is configurable via web user interface at the path **Home->DND**.

Ending Calls

During a two-way call, do one of the following to end the call.

- Press  on the remote control.
- Press  or the **End Call** soft key on the video conferencing phone.
- Click **Hang Up All** button on the web user interface.
The interface prompts "Hang up?"
Click **Confirm** to end the call.



During a multi-way call, do one of the following to end the call.

- Press  on the remote control.
The display device prompts "End all active calls?"
Select **Yes**, and then press .
- Press  or the **End Call** soft key on the video conferencing phone.
The LCD screen of the video conferencing phone prompts "End All Active Calls?"
Press  or the **Yes** soft key to end all calls.
- Click **Hang Up All** button on the web user interface.
The interface prompts "Hang up?"



Click **Confirm** to end the call.

During a multi-way call, you can remove any party via the remote control or web user interface.

To remove any party via the remote control:

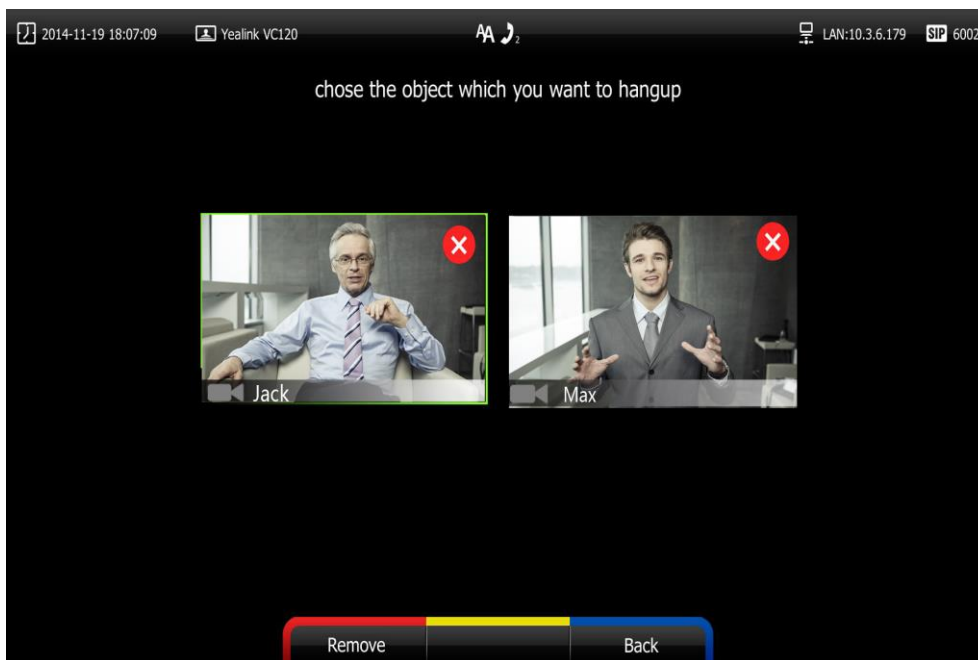
1. Press  (**More** soft key) during a multi-way call.
2. Press ▲ or ▼ to scroll to **Remove**, and then press .



3. Select the party you want to remove, and then press .
4. Press  (**Remove** soft key).

To remove any party from a multi-way call via web user interface, go to the path **Home** (Hover your cursor over of the number of remote system, and then click ).

Call Management

You can enable mute mode, record video, control the video and change video layout during an active call.

Call Mute

You can enable mute mode to mute the microphone of the active audio device during an active call, and then the other party cannot hear you.



Do one of the following:

- Press  on the remote control.
- If VCM30 is connected to the Audio In port of VC120 codec.

You can tap  on the top of the VCM30 to mute the call. The mute indicator LED will

illuminate solid red.

- If video conferencing phone is connected to the Audio In port of VC120 codec:

You can press  on the video conferencing phone to mute the call. If CPE80 expansion microphones are connected to the video conferencing phone, you can also tap  on the CPE80 expansion microphones to mute the call.

Mute Indicator LEDs on the video conferencing phone and CPE80 will illuminate solid red.

And the LCD screen of the video conferencing phone is shown as below:



- Log into the web user interface, check the **Mute** checkbox.

If video conferencing system is muted, the  icon will appear on the local video.

Call Statistics

If voice quality is poor during a call, you can enter the Call Statistics screen to view the current status of the call to find out why.

Codec, bandwidth, total packet lost and other parameters about presentation are included in the call statistics. For example, when a delay occurs or the video has a 'mosaic' look, you can view the total packet loss to check whether the packet has been lost.

Call statistics is configurable via the remote control or web user interface.

To view call statistics via the remote control:

1. Press  (**More** soft key) during an active call.

2. Press ▲ or ▼ to scroll to **Call Statistics**, and then press  to enter the **Call Statistics** screen.



Type	Total Bandwidth	Recv(2064 kb/s)	Send(1602 kb/s)	Codec	G.722.1C	G.722.1C
Video	Resolution	1920 X 1080	1920 X 1080	Audio	Bandwidth	48 kb/s
	Codec	H.264 High Profile	H.264 High Profile		Sample Rate	32 k
	Bandwidth	2016 kb/s	1554 kb/s		Jitter	0 ms
	Frame Rate	30 fps	25 fps		Total Packet Lost	0
	Jitter	29 ms	17 ms		Packet Lost(%)	0%
	Total Packet Lost	0	0		Resolution	--
Protocol	H.323	Share		Codec	--	
	Device Info			Yealink VC110 50.21.0.18 38/2	Bandwidth	--
	Frame Rate			--		

3. Press  (**More** soft key) to return.

To view call statistics via web user interface, go to the path **Home** (Hover your cursor over the other party on the left side of the screen, and then click ).

Presentation

The system supports sharing video and documents on a PC while simultaneously displaying the main video. We recommend using dual display devices for sharing contents. During a call, if a PC is connected to the VC120 codec, the system will start a presentation automatically. Both local and remote display devices will share contents.

You can also start/stop presentation during a call via the remote control or video conferencing phone (ensure a PC is connected to the VC120 codec). If you disconnect the PC, the presentation will end automatically.

Only one presentation can be shared at a time. A presentation started later will replace the previous presentation.



To start/stop presentation during a call:

Do one of the following:

- Press  (**Presentation** soft key) on the remote control to start a presentation.

Press  (**Presentation** soft key) on the remote control again to end a presentation.



- Press  on the video conferencing phone to start a presentation.
- Press  again to end a presentation.

To start/stop presentation during a call by changing the video input source:

1. Press .

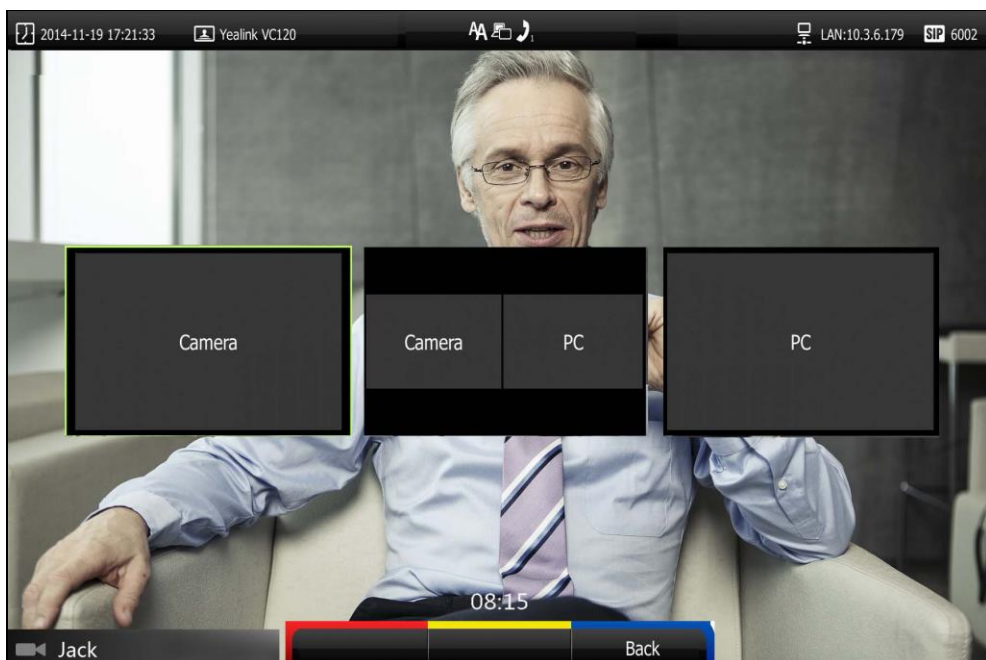

The display device shows **Camera, Camera and PC and PC** input sources.



- If you select **PC**, the remote video image is shown in big size, and the PC presentation along the right side of the screen is shown in small size.

- If you select **Camera and PC** or **PC**, the PC presentation is shown in big size, and other video images along the right side of the screen are shown in small size.
- If you select **Camera**, the remote video image is shown in big size, and local video image along the right side of the screen is shown in small size. The presentation ends.

Note You can connect two VCC20 cameras to the VC120 Codec using the VC Dual-camera Box VCB20 (You should purchase it separately if necessary). For more information, refer to [Changing the Video Input Source](#) on page 123.

Changing the Video Layout

During a conference call, local and remote video images are displayed on the display device. You can change the screen layout. The system supports three screen layouts.

- One big, one small (): The selected video image is shown in a big size format, the other video image along the right side of the screen is shown in small sizes.
- Full screen (): The selected video image is shown in full size.
- Same size (): All video images are shown in the same size.

One display devices (single screen) is connected to the VC120 codec, the default screen layout is described below:

- When there is one active call and local system does not start a presentation, the remote video image is shown in full size.

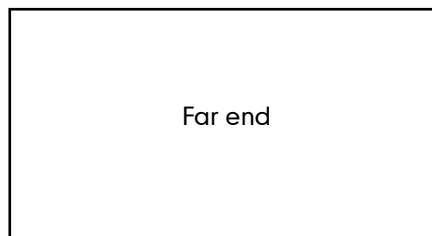

- When there are multiple active calls (take 4 parties as an example) and the local system does not start a presentation, both local and remote video image are shown in the same size.

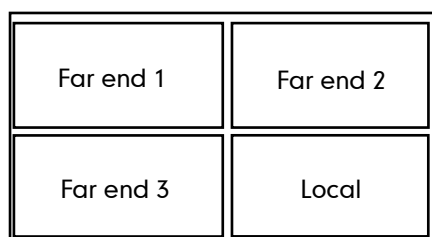

- When local system is sharing a presentation during a call, the presentation will be shown in big size, and other video images will be shown in small sizes.

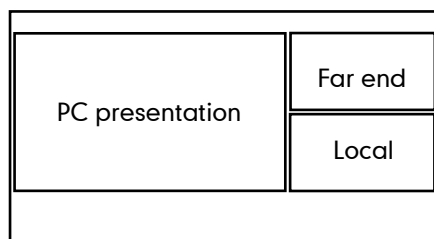

To change screen layout via the remote control:

1. Press  (**Layout** soft key) during an active call.

The display device shows all video thumbnails and three layout soft keys.

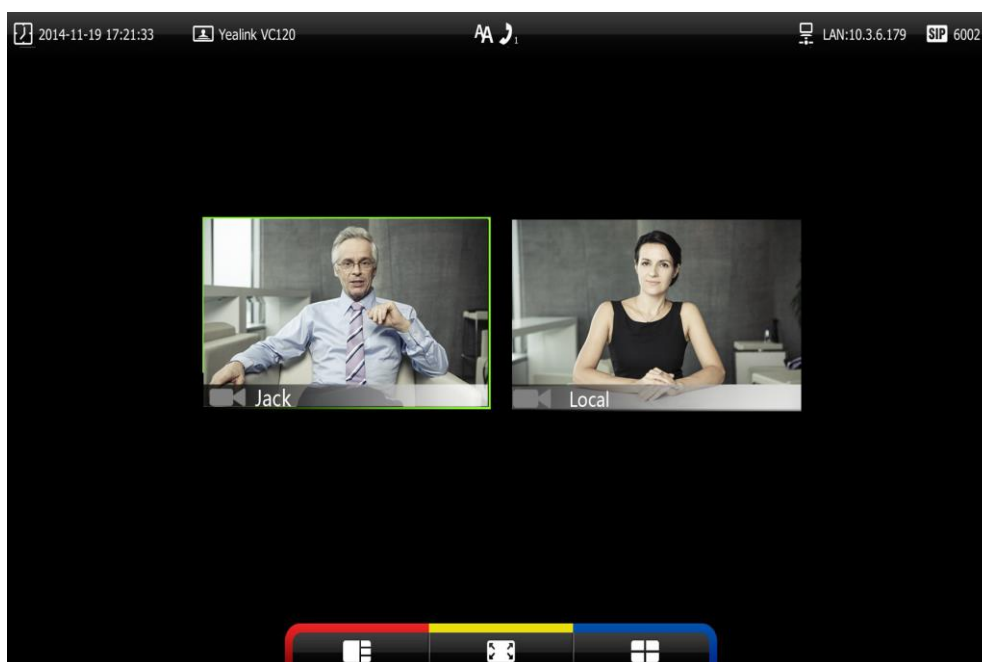

2. Press ◀ or ▶ to select a video.
3. Press the desired layout soft key.

For example, if you select , the video layout will be shown as below.

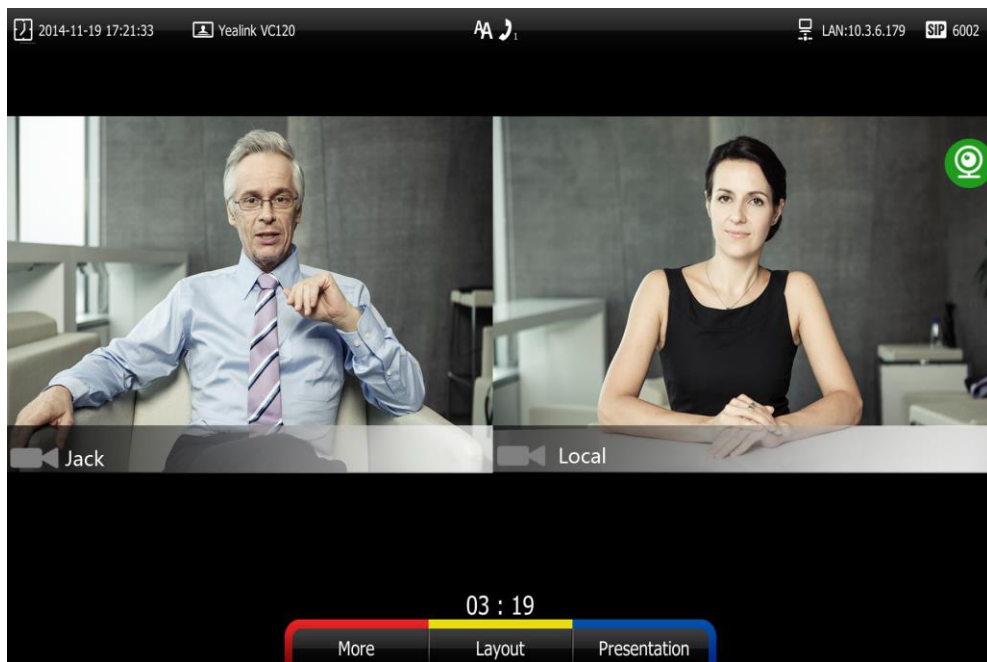

Dual Screen

The VC120 has two display ports. When connecting only one display device to the VC120 codec, Display1 port is the only available port. To make it easier for users to view video images, users can connect two display devices to Display1 and Display2 ports respectively. When two display devices are connected to the VC120 codec, the status bar of the primary display device will display  icon.

Two display devices (dual screen) are connected to the VC120 codec:

- When the system is idle and does not start a presentation.

In the primary display device, the local video image is shown in full size.

In the secondary display device, the local video image is shown in full size (no menu and status bar).

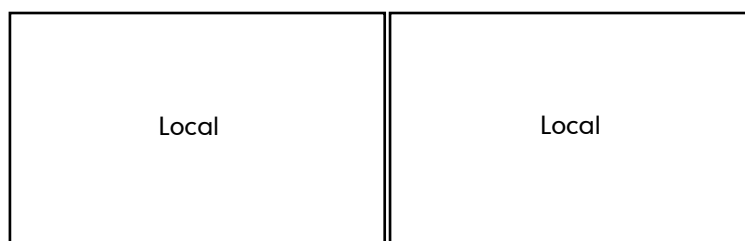

Primary display device

Secondary display device

- When the system is idle and starts a presentation.

In the primary display device, the local video image is shown in full size.

In the secondary display device, the presentation is shown in full size (no menu and status

bar).

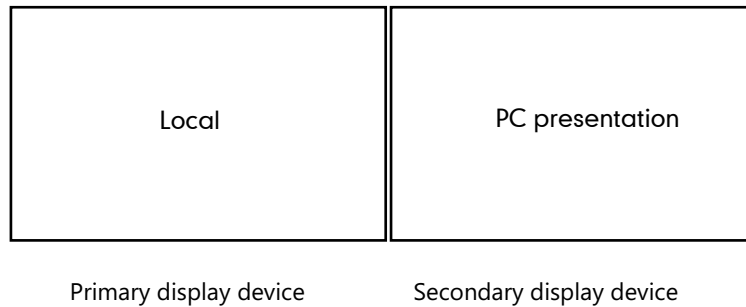

- When the system is during a call and does not start a presentation.
In the primary display device, the remote video image is shown in full size.
In the secondary display device, the local video image is shown in full size.

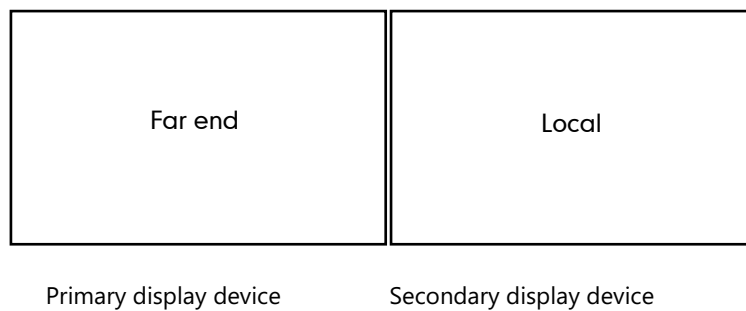

- When the system is during a call and starts a presentation.
In the primary display device, the remote video image is shown in big size, local video image along the right side of the screen is shown in small size.
In the secondary display device, the presentation is shown in full size.

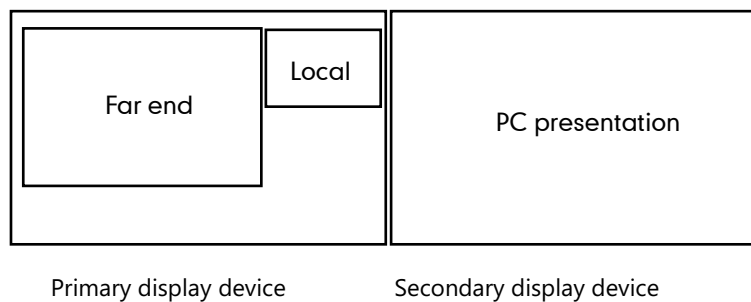

- When the system is during multiple active calls (take 4 parties as an example) and does not start a presentation.
In the primary display device, the video images are shown in the same size.

In the secondary display device, the local video image is shown in full size.

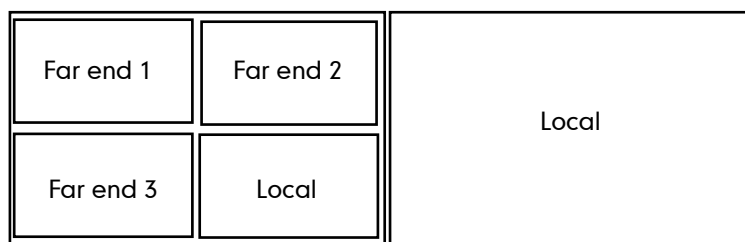

Primary display device

Secondary display device

- When the system is during multiple active calls (take 4 parties as an example) and starts a presentation.

In the primary display device, the video images are shown in the same size.

In the secondary display device, the presentation is shown in full size.

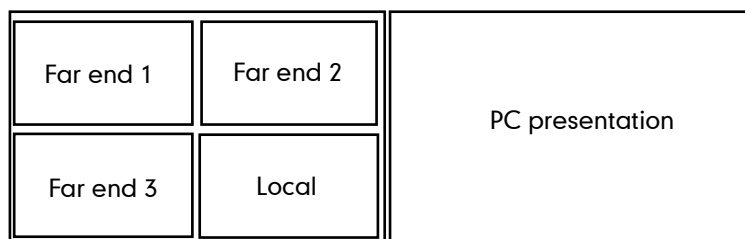





Primary display device

Secondary display device

You can specify the display content on the secondary display device via the remote control.

To specify the display content on the secondary display device via the remote control:

1. Press the **More** soft key during an active call.
2. Select **Focus (Display2)**, and then press .
3. Press  or  to select the desired content, and then press .

The secondary display device displays the selected content. The  icon is displayed on the focus content.

After reassigning the display content on the secondary display device, the presentation will automatically be displayed on the primary display device.

Controlling the Camera

Before placing a video call, you need to be familiar with how to adjust the angle and focus of the camera. After any adjustment, you can long press numeric key (0-9) to associate the position of the camera with this key.

Adjusting the Camera



Avoid physically adjusting the camera to prevent damaging it. Always use the remote control to control the camera.

To control the camera when the system is idle via the remote control:

1. Press the navigation key to adjust the angle of the camera.

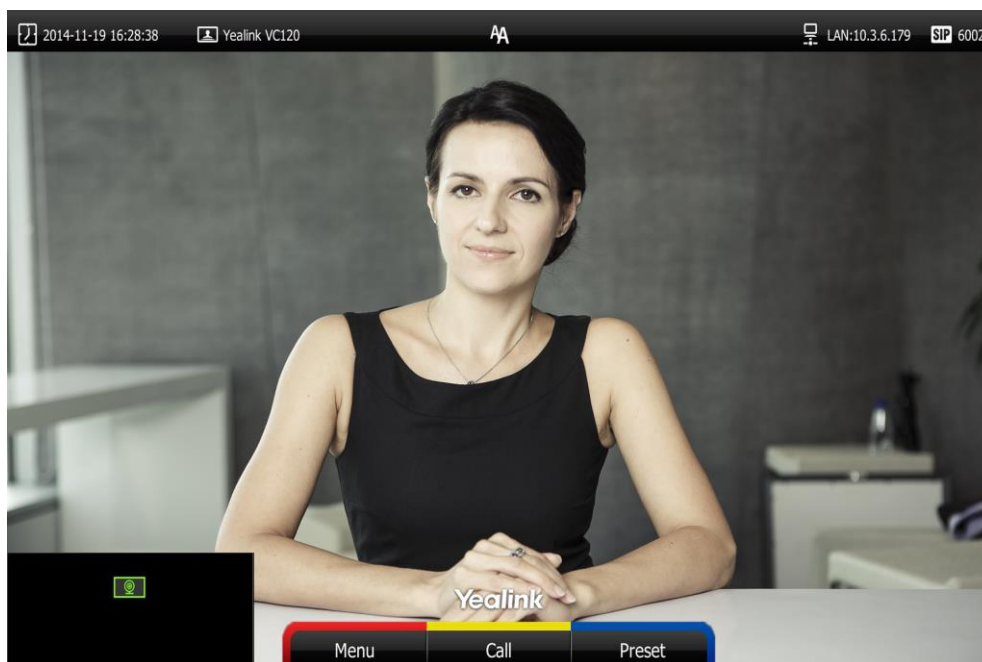
The display device shows the current angle of the camera.



2. Press  or  to adjust the focus of the camera.

The display device shows the focus of the camera.

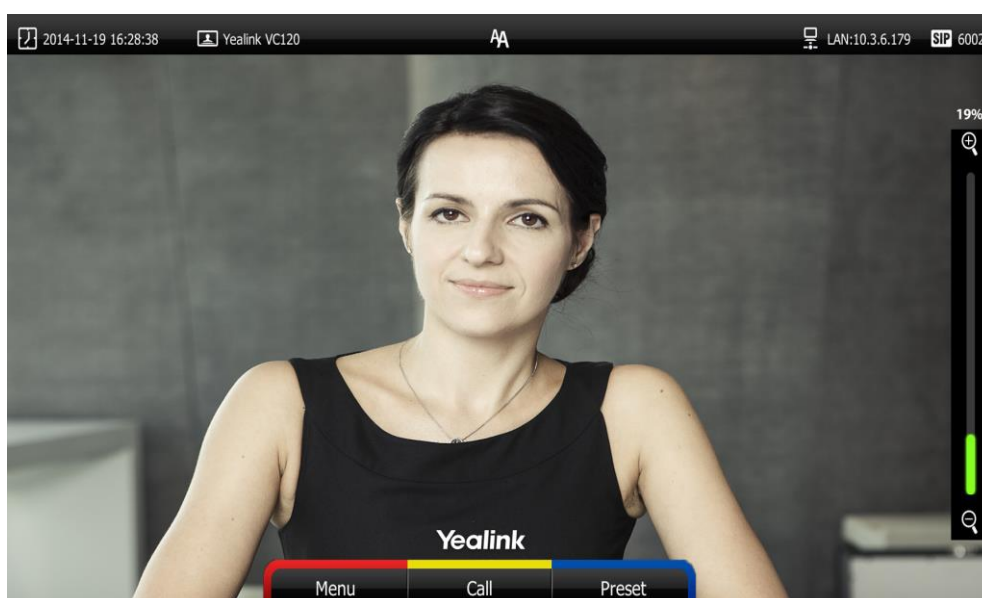



Configuring Camera Presets

Up to 10 presets can be assigned to the numeric key. Each camera preset stores the camera pan, tilt, and zoom settings. You can store the preset to a numeric key via the remote control or web user interface. This means that you can adjust the camera to the preset position by pressing a

stored key.



To save the preset of the camera when the system is idle:

1. Press  (**Preset** soft key).
2. Press the navigation key to adjust the angle of the camera or press  or  to adjust the focus of the camera.
3. Long press any number key (0-9) on the remote control until the screen prompts "Preset Key 'X' successfully saved" ("X" stands for the saved key).







Current camera position and focus are stored to the numeric key. You can change the position of the camera and focus to the preset quickly by pressing the saved key during a call.

4. Press  (**Exit** soft key) to return to the idle screen.

To adjust the camera to the preset via the remote control when the system is idle:





1. Press  (**Preset** soft key).
2. Press the numeric key that is already associated with a preset.
The camera will adjust to the preset.
3. Press  (**Exit** soft key) to return to the idle screen.

To control local camera via the remote control during a video call:

1. Press  (**More** soft key) during an active call.
2. Press  or  to scroll to **Camera Preset**, and then press .
3. Press the navigation key to adjust the angle of the camera or press  or  to adjust the focus of the camera.
4. Long press any numeric key (0-9) to save the current preset position of the camera.
The original preset will be overwritten if you configure a preset for the numeric key that is already associated with a preset.
5. Press  (**Exit** soft key) to return to the idle screen.







To control the local camera during a video call via web user interface, go to the path **Home** (Hover your cursor over the registered account, click , and then control the camera in the pop-up window).

To adjust the camera to the preset via the remote control during a video call:





1. Press  (**More** soft key) during an active call.
2. Press  or  to scroll to **Camera Preset**, and then press .
3. Short press the saved key to change camera position and focus to the preset.
4. Press  (**Exit** soft key) to return to the idle screen.

If the remote camera enables the far-end camera control feature (For more information, refer to [Far-end Camera Control](#) on page 91) and corresponding camera control protocol is enabled (For more information, refer to your system administrator), you can control the remote camera during the video call via the remote control.

To control remote camera via the remote control during a video call:

1. Press  (**More** soft key) during an active call.
2. Press ▲ or ▼ to scroll to **Near/Far Camera**, and then press .
3. Select the remote video, and then press .
4. Press  (**More** soft key).
5. Press ▲ or ▼ to scroll to **Camera Preset**, and then press .
6. Short press the saved key to change remote camera position and focus to the preset (The preset is set by the remote system in advance).
7. Press  (**Exit** soft key) to return to the idle screen.

To clear preset via the remote control:

1. Press  (**Menu** soft key) to enter main menu.
2. Press ◀ or ▶ to select the **Video & Audio** menu.
3. Press ▲ or ▼ to scroll to **Camera General Settings**, and then press .
4. Press ▲ or ▼ to scroll to **Clear Preset Position**, and then press .
5. Select OK, and then press  to delete all presets.

Controlling Dual Cameras

You can connect two VCC20 cameras to the VC120 Codec using the VC Dual-camera Box VCB20 (You should purchase it separately if necessary). You can switch the images between these two cameras freely according to your need. For more information, refer to [Changing the Video Input Source](#) on page 123.

When controlling dual cameras, you need to know the following:

- The display device displays the image captured from the camera 1 by default.
- The display device will display the image captured from the camera 2 once you unplug the camera 1. When you are using camera 1, unplug the camera 2 will not affect the current image.
- Camera Preset are assigned to Camera 1 or Camera 2 separately. They don't impact each other.

For more information on VCB20, refer to [Yealink VC Dual-camera Box VCB20 Datasheet](#).

Changing the Video Input Source

VC120 video conferencing system supports these video input sources: camera and PC.

When the camera and PC are connected to the VC120 codec, the display device displays the presentation on the connected PC.

If two VCC20 cameras are connected to the VC120 Codec, you can switch the images between these two cameras freely.

If two display devices are connected to the VC120 codec, the video image is shown on the main

display device, and the presentation is shown on the secondary display device.

During a call, the display device will display differently depending on whether it has been connected to a secondary display device and the video input source you select. You can change the video input source via the remote control and web user interface.

To change video input when the system is idle via the remote control:

1. Press .

The display device shows **Camera** and **PC** input sources.
2. Press ◀ or ▶ to select the desired input source, and then press .

The display device shows the selected source.

To change video input during a call:

1. Press .

The display device shows **Camera**, **Camera and PC** and **PC** input sources.
2. Press ◀ or ▶ to select the desired input source, and then press .

The display device shows the selected source.

Video input is configurable via web user interface at the path **Home->Input**.

Video Recording



When the system is idle, you can record local video via the remote control. During a call, the video and presentation which are shown on the display device can be recorded via the remote control and video conferencing phone.

Before recording video, you need to insert a USB flash drive into the USB port on the VC120 codec to store recorded video and make sure the USB feature is enabled. For more information, please refer to [USB Configuration](#) on page 70. The recorded video will be saved in .mkv format and named as the recorded time and date. Video can be played on either the system itself or on a computer using an application capable of playing .wav files.

Note

The system only supports USB flash drive in FAT32 format.

After the USB flash drive is inserted to the USB port on the VC120 codec and the USB feature is enabled, the display device will prompt "USB device available, press * to record or press # to screenshot".

The  icon will appear on the status bar of the display device, and the  icon will appear on the LCD screen of the video conferencing phone.

Before recording video, you need to know the following:

- When recording video, it is not allowed to play or delete the video from the menu.
- When recording video, it is not allowed to capture screenshots, but you can view and delete screenshots.
- When playing video recording, it is not allowed to record again. But when the video is

paused, you can press  to record again.

- When receiving or making a call, it is not allowed to record.
- When there is an incoming call during recording, the system will quit recording.
- When recording during a video call, the record will be finished automatically after the call ends.
- When playing or recording video, it is unavailable to press  to return to the idle screen.
- When playing, recording or pausing video, the system will not go to sleep automatically.
- If you remove the working USB flash drive or insert another USB flash drive during recording, the recording will be stopped.

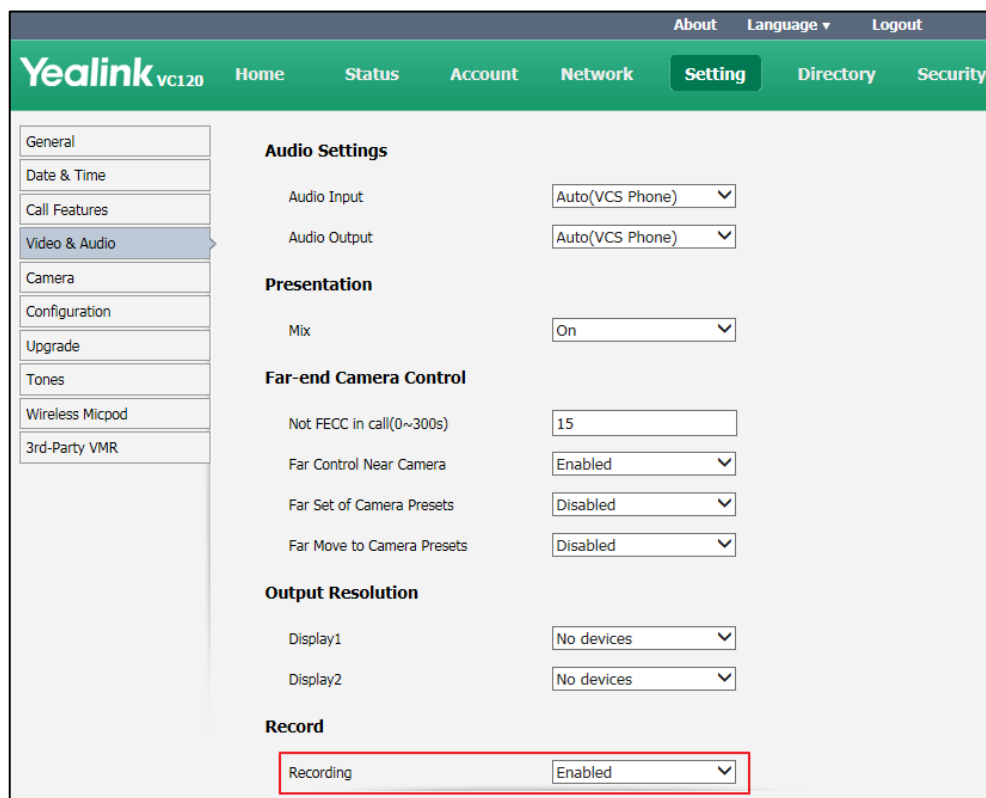

To configure video recording via web user interface:

1. Click on **Setting->Video & Audio**.
2. Select the **Enabled** from the pull-down list of **Recording**.









3. Click **Confirm** to accept the change.

To record video when the system is idle via the remote control:

1. Press  to start recording and press  again to stop recording.

To record video during a call via the remote control:

1. Do one of the following:

- Long press  to start recording and long press  again to stop recording.
- Press  (**More** soft key) to open **More** screen.
Press  or  to scroll to **USB Recording**, and then press  to start recording.
Open the **More** screen, scroll to **USB Recording** again, and then press  to stop recording.

To record video during a call via the video conferencing phone:

1. Press the **Start REC** soft key to start recording and press the **Stop REC** soft key again to stop recording.











When you start recording, the display device will show  and the recording time. When you stop recording, the recording icon disappears from the screen. The display device prompts "Successfully video recording!"

Note









If you start recording during a call, both your display device and remote display devices will show the  icon on your video image.

To view recorded video via the remote control:

Insert the USB flash drive with the recorded video to the VC120 codec.



1. Press  (**Menu** soft key) to enter main menu.
2. Press  or  to select the **Record** menu.
3. Press  or  to scroll to **Videos**, and then press .
4. Press  or  to select the desired **Video**.
5. Press  or  (**Play** soft key).



You can do the following:

- To pause the video, press  (**Pause** soft key). The  (**Play** soft key) appears on the LCD TV screen.
Press  (**Play** soft key) to continue playing video.
- To skip forward the video, press . Press once to skip forward 8 seconds.
- To rewind the video, press . Press once to rewind 8 seconds.
- To adjust the volume of the speakerphone, press  or .
- To stop the video, press  (**Stop** soft key).

When receiving an incoming call while you are playing video, the system will stop playing video automatically.

To delete recorded video via the remote control:

1. Press  (**Menu** soft key) to enter main menu.
2. Press  or  to select the **Record** menu.

3. Press ▲ or ▼ to scroll to **Videos**, and then press .
4. Press ▲ or ▼ to select the desired **Video**.
5. Press  (**Delete** soft key).

The display device prompts "Delete this video?"

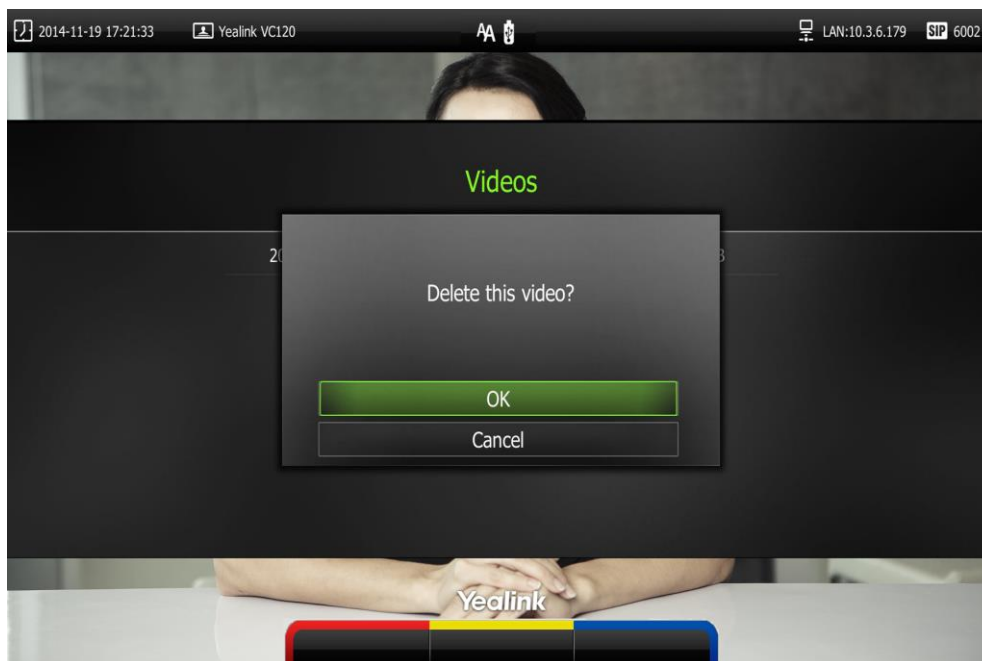

6. Select **OK**, and then press  to delete the video.

Auto Recording

Auto recording feature is available only when the recording feature is enabled. If it is enabled, the system will start recording automatically once a call is established. Make sure a USB flash drive has been inserted to the USB port on the VC120 Codec and the USB feature is enabled. You can configure auto recording feature via web user interface only.

To configure auto recording feature via web user interface:

1. Click on **Setting->Video & Audio**.

2. Select the desired value from the pull-down list of **Auto Recording**.

The screenshot shows the Yealink VC120 web interface. The top navigation bar includes 'About', 'Language', and 'Logout'. The main menu has 'Home', 'Status', 'Account', 'Network', 'Setting' (highlighted), 'Directory', and 'Security'. The left sidebar lists various settings categories: General, Date & Time, Call Features, Video & Audio (selected), Camera, Configuration, Upgrade, Tones, Wireless Micpod, and 3rd-Party VMR. The main content area is titled 'Setting' and contains several sections: 'Audio Output' (Auto(VCS Phone)), 'Presentation' (Mix: On), 'Far-end Camera Control' (Not FECC in call(0~300s): 15, Far Control Near Camera: Enabled, Far Set of Camera Presets: Disabled, Far Move to Camera Presets: Disabled), 'Output Resolution' (Display1: Auto(1920 x 1080 60H), Display2: No devices), and 'Record' (Recording: Enabled, Auto Recording: Disabled, Screenshot: Enabled). The 'Auto Recording' dropdown is highlighted with a red box. At the bottom, there are 'Confirm' and 'Cancel' buttons.

3. Click **Confirm** to accept the change.

Screenshot

You can capture the screenshot from the camera via the remote control or web user interface. You need to insert a USB flash drive to the USB port on the VC120 codec to store screenshots when you are using remote control and make sure the USB feature is enabled. For more information, please refer to [USB Configuration](#) on page 70.

You can view, delete or scale the screenshots via the remote control.

When you capture a screenshot via web user interface, you can save the screenshots to the computer. The stored screenshot will be saved in .jpg format and named as the captured time and date. You can view the screenshot using an application capable of viewing .jpg pictures.

Note

The system only supports USB flash drive in FAT32 format.

After the USB flash drive is inserted to the USB port on the VC120 codec and the USB feature is enabled, the display device will prompt "USB device available, press * to record or press # to screenshot".

The  icon will appear on the status bar of the display device, and the **USB** icon will appear on the LCD screen of the video conferencing phone.

The system supports capturing one screenshot per second.



Before capturing screenshots, you need to know the following:



- When receiving or making a call, it is not allowed to capture screenshots.
- When recording video, it is not allowed to capture screenshots.
- If two USB flash drives are connected, and you remove the working USB flash drive, the remained one can continue to work seamlessly.

To capture screenshots when the system is idle via the remote control:

1. Press  .











To capture screenshots during a call via the remote control:

1. Press  .
 - Long press  .
 - Press  (**Menu** soft key) to open **More** screen.





Press  or  to scroll to **Screenshot**, and then press  to capture screenshots.

The  icon at the status bar of the display device shows "+1" animated effects.









To view screenshots via the remote control:

1. Press  (**Menu** soft key) to enter main menu.
2. Press  or  to select the **Record** menu.
3. Press  or  to scroll to **Screenshots**, and then press  .
4. Press  or  to select desired screenshots.
5. Press  or  (**View** soft key).

You can do one of the following:

- Press  or  to view previous or next screenshot.
- Press  or  to zoom screenshot in/out.
- Press  (**Original size** soft key) to view the original size of the screenshot.

To delete screenshots via the remote control:

1. Press  (**Menu** soft key) to enter main menu.
2. Press  or  to select the **Record** menu.
3. Press  or  to scroll to **Screenshots**, and then press  .
4. Press  or  to select desired screenshots.
5. Press  (**Delete** soft key).

The display device prompts "Delete this screenshot?"

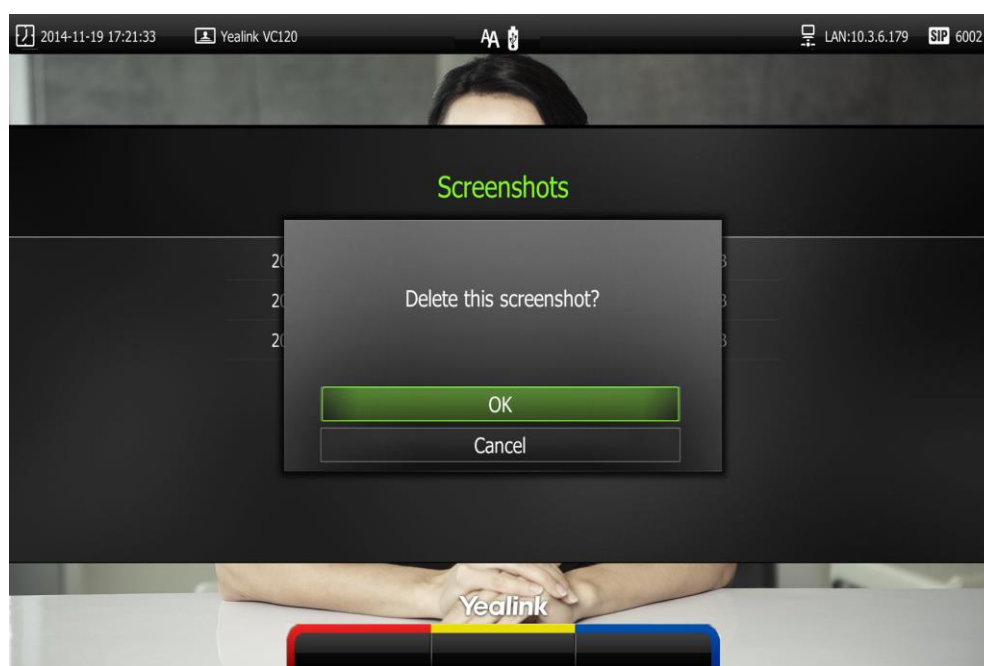

6. Select **OK**, and then press **OK** to delete the screenshot.

Screenshot is configurable via the web user interface at the path **Setting->Video & Audio->Screenshot**.

Capture the screenshot via web user interface at the path **Home->Screenshot**.

8-Way Conference License

The basic version of VC120 video conferencing system m supports up to 2-way video calls and an additional voice call (an original caller and two other sites). You can import an 8-way conference license to extend the VC120 to support 8-way video calls and an additional voice call (an original caller and eight other sites). 8-way conference license is configurable via web user interface only.

VC120 video conferencing system supports a permanent version of the 8-way conference license and a trial version of the 8-way conference license. They have the same feature.

- **Permanent version of the 8-way conference license:** each VC120 has a unique license. The license cannot be used for other systems. You need to contact Yealink resellers to purchase it, please provide the MAC address of your VC120 when purchasing.
- **Trial version of the 8-way conference license:** VC120 models can share this license. You can download a 30-day trial from Yealink website.

To import the 8-way conference license via web user interface:





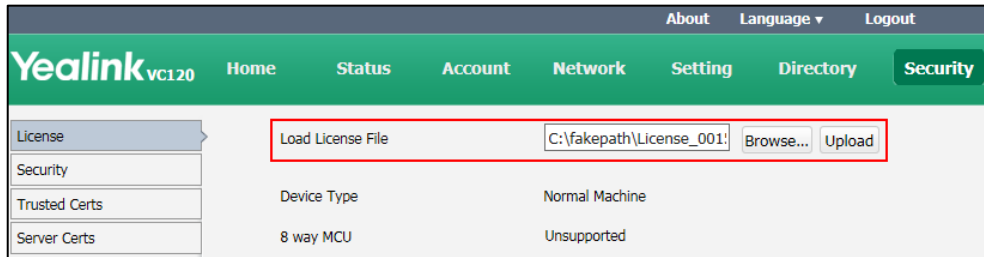

1. Click on **Security ->License**.

- Click **Browse** to locate the 8-way conference license (the file format must be *.dat) from your local system.



- Click **Upload** to complete importing the 8-way conference license.

To view 8-way conference license status via the remote control:

- Press  (**Menu** soft key) to enter main menu.
- Press  or  to select the **Status** menu.
- Press  or  to scroll to **License**, and then press  .
 - If the 8 way MCU displays **Unsupported**, it means you have not imported an 8-way conference license. So the system supports up to 2-way video calls and an additional voice call (an original caller and two other sites)

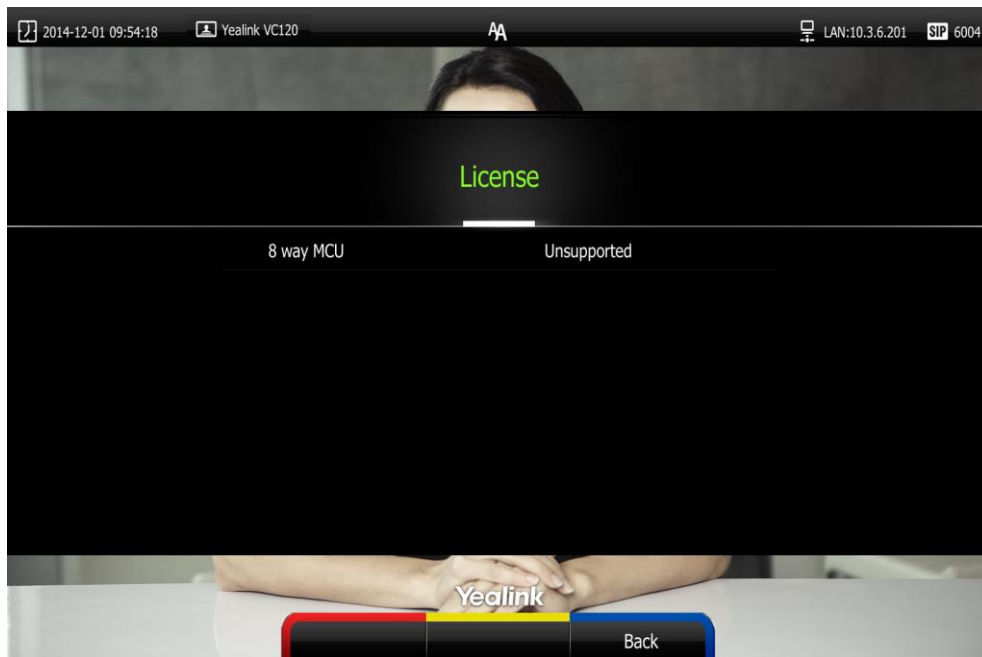

- If the 8 way MCU displays **X~Y Available**, it means you have imported a trial version of 8-way conference license. So the system supports up to 8-way video calls and an additional voice call (an original caller and eight other sites) in X~Y period. When the trial license expires, your system supports 2-way video calls and an additional voice call (an original caller and two other sites)

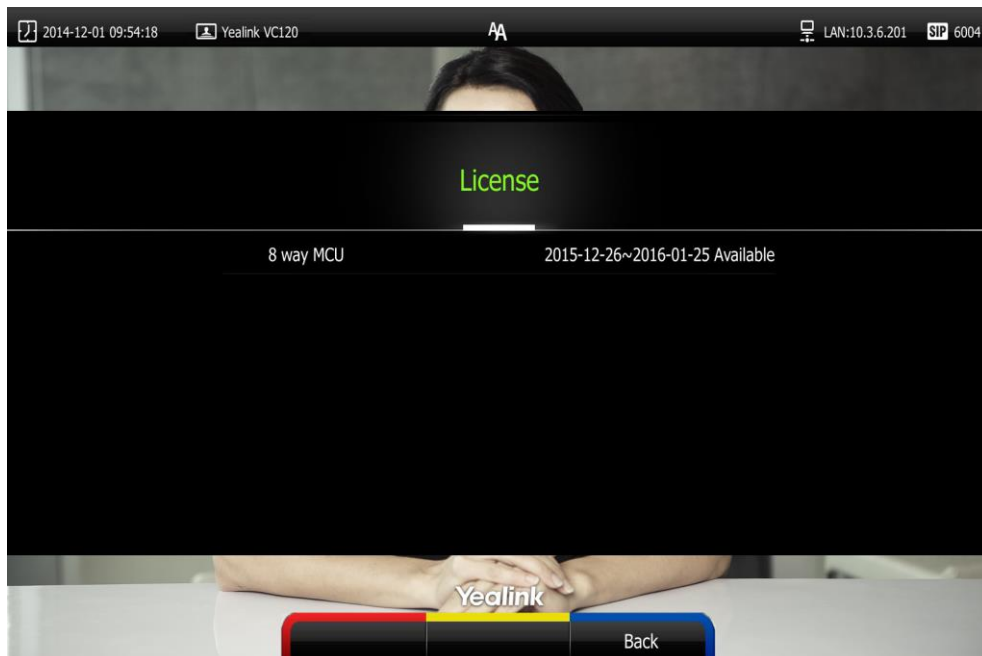

- If the 8 way MCU displays **Eternal**, it means you have imported a permanent version of the 8-way conference license. So the system supports up to 8-way video calls and an additional voice call (an original caller and eight other sites) permanently.

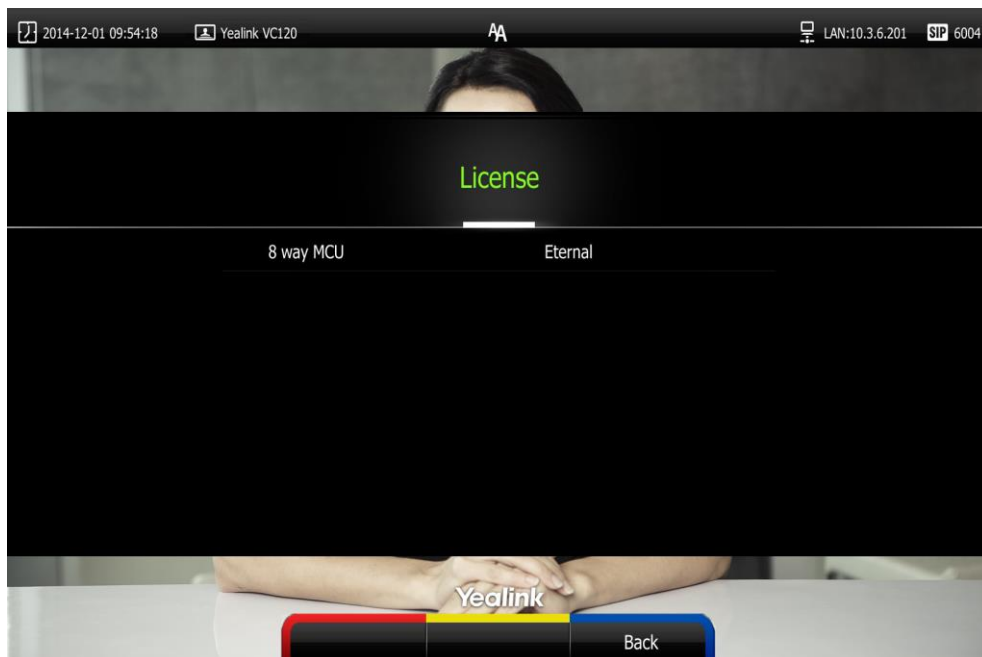

8-way conference license status can be viewed via web user interface at the path

Status->License.

Note

Upgrading the system or performing a factory reset will not affect the imported 8-way license.

If the system has been imported a trial version of the 8-way license and the license has not expired, and you import a permanent version to the system, the permanent version will overwrite the trial version.

If the system has been imported a permanent version of the 8-way license, and you import a trial version to the system, the permanent version will not be overwritten.

For more information on how to set up an 8-way conference, refer to [Placing Multiple Calls](#) on page 98. By default, all video images are shown in the same size after the conference call is set up.

Using Cloud Platform

Yealink video conferencing system is compatible with StarLeaf/Zoom/Pexip/BlueJeans/Mind platform.

Users can access Virtual Meeting Rooms(VMR) using Yealink video conferencing system, whilst benefiting from both the features provided by Yealink, such as 1080p HD video and audio, and features provided by StarLeaf/Zoom/Pexip/BlueJeans/Mind, including high end customization & interoperability.

If you don't log into Cloud platform or you only log into the Yealink Cloud platform, you can configure the address of the third-party platform in advance, the platform names will appear on your display device at the path **Call-> Dial->Call Type**. Even if you don't log into the third-party platform, you can also select the desired third-party platform to call corresponding VMRs quickly. For more information, refer to [Yealink VC400 & VC120 Video Conferencing System Administrator Guide](#).

This chapter provides the information about using the Cloud platform. Topics include:

- [Using the Yealink Cloud Platform](#)
- [Using the StarLeaf Cloud Platform](#)
- [Using the Zoom Cloud Platform](#)
- [Using the BlueJeans Cloud Platform](#)
- [Using the Pexip Platform](#)
- [Using the Mind Platform](#)
- [Using the Custom Platform](#)



Using the Yealink Cloud Platform

You can log into the Yealink Cloud platform, and dial other Yealink Cloud numbers to establish calls.

When using the Yealink Cloud account, the VC120 video conferencing system supports 2-way video calls (an original caller and one other site). If an 8-way conference license has imported to the VC120, it can support up to 4-way video calls (an original caller and three other sites).



Dialing Yealink Cloud Numbers

To dial Yealink Cloud numbers via the remote control:

1. Press  (**Call** soft key) or  to enter the dialing screen.
2. Select **Yealink Cloud** from the pull-down list of **Call Type** before connection.

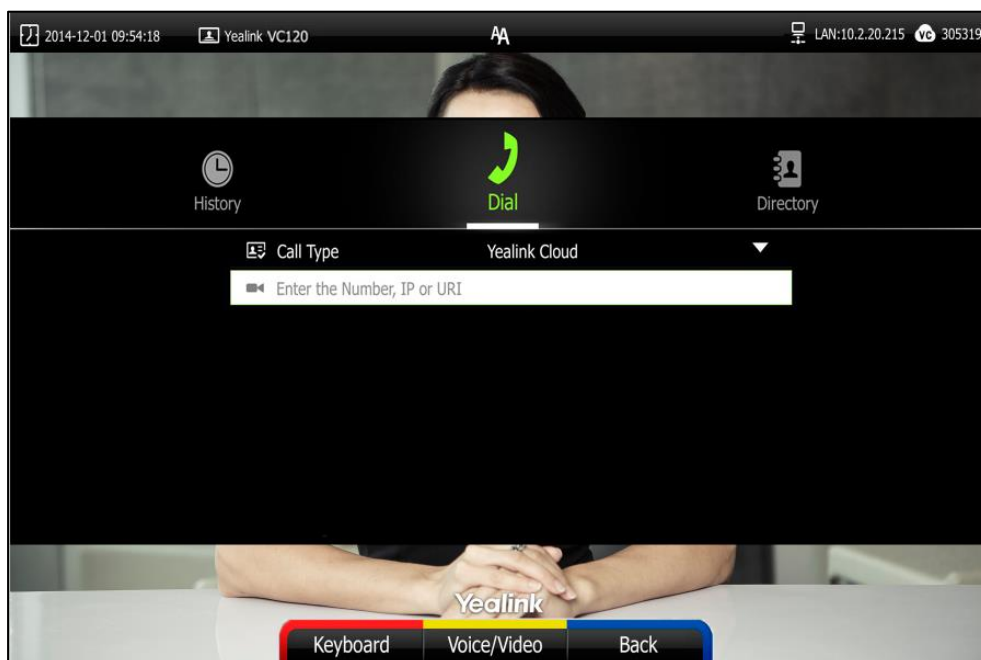
3. Enter the desired number, IP or URI using the keypad or the on-screen keyboard.



4. Press  (**Voice/Video** soft key) to change call mode.
5. Press  or .

Note

If you want to place a call to a Yealink Cloud contact who is in the same enterprise directory as you, you can enter Yealink Cloud numbers or the extension (the last four Yealink Cloud numbers) to place a call. If you want to place a call to a Yealink Cloud contact who is in different enterprise directory from you, you can only enter Yealink Cloud numbers to place a call.

If you log into Yealink Cloud platform using the built-in Cloud number, your directory will not include the Cloud contacts, but you can dial other built-in Cloud number or Yealink Cloud numbers to call other Cloud contacts.

Cloud call is encrypted by default. You will see an encryption icon  during a Cloud call.

Using the StarLeaf Cloud Platform



You can log into the StarLeaf Cloud platform.

When you place a call using the StarLeaf Cloud account, you can:

- Call the other StarLeaf Cloud account to establish a point to point call.
- Call the Meeting ID to join the Virtual Meeting Rooms.
- Call between StarLeaf Cloud account and Microsoft Skype for Business/Lync account.

Dialing StarLeaf Cloud Numbers

To dial StarLeaf Cloud numbers via the remote control:

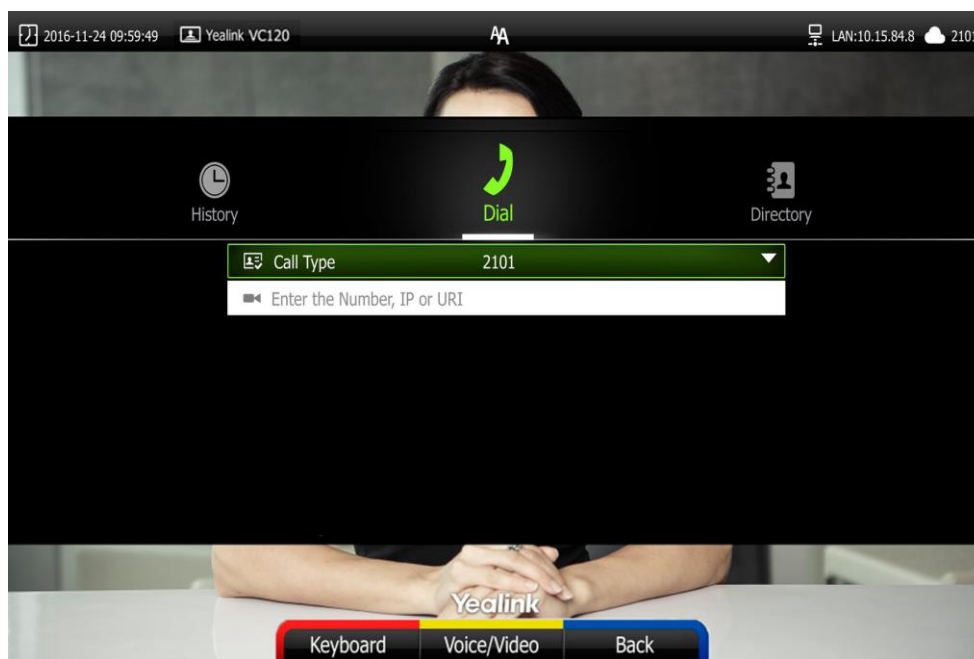

1. Press  (**Call** soft key) or  to enter the dialing screen.
2. Select the registered StarLeaf Cloud number from the pull-down list of **Call Type**.
3. Enter a StarLeaf Cloud number using the keypad or the on-screen keyboard.



4. Press  (**Voice/Video** soft key) to change call mode.
5. Press  or .



Joining the StarLeaf Meeting

To join the StarLeaf meeting via the remote control:

1. Press  (**Call** soft key) or  to enter the dialing screen.
2. Select the registered StarLeaf Cloud number from the pull-down list of **Call Type**.

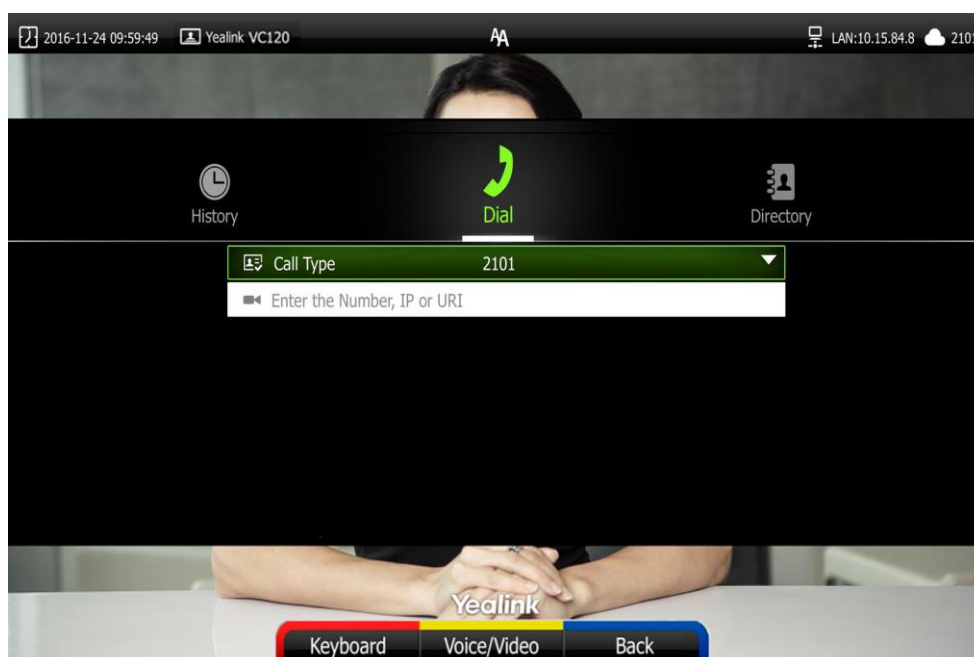
3. Enter the meeting ID using the keypad or the on-screen keyboard.





4. Press  (**Voice/Video** soft key) to change call mode.
5. Press  or  to join the StarLeaf meeting.

Using the Zoom Cloud Platform

You can log into the Zoom Cloud platform, and join the Zoom meeting.



Joining the Zoom Meeting

To join the Zoom meeting:

1. Press  (**Call** soft key) or  to enter the dialing screen.
2. Select **Zoom** from the pull-down list of **Call Type** before connection.

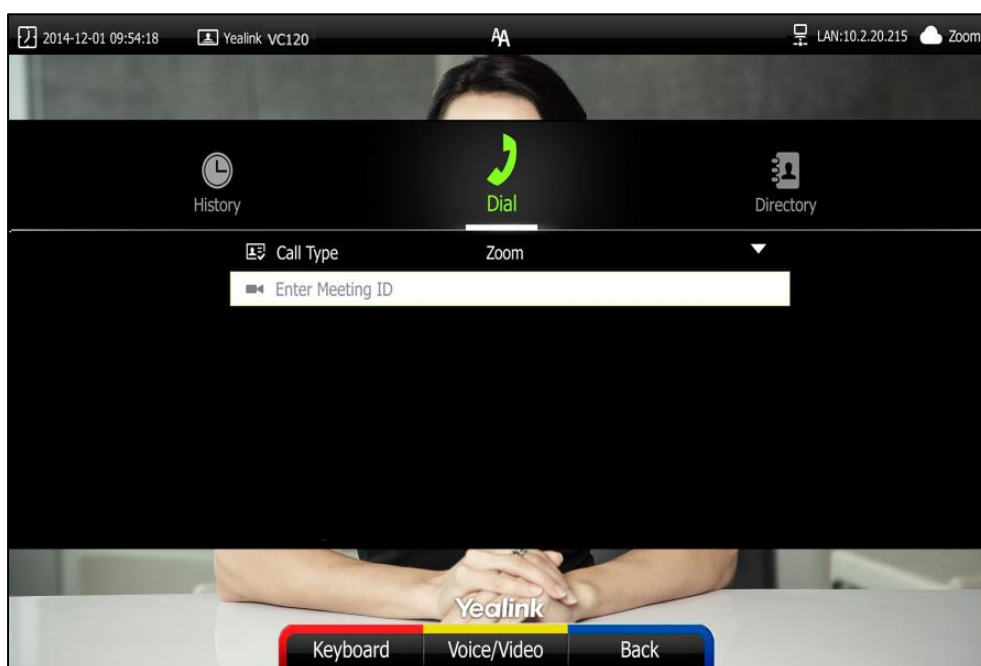
3. Enter meeting ID using the keypad or the on-screen keyboard.



4. Press  (**Voice/Video** soft key) to change call mode.
 5. Press  or .
- You will enter the Zoom welcome screen.
6. Follow the voice prompt to join the Zoom meeting.

Note



If you enter nothing or enter wrong information, you can still be sent to the Zoom welcome screen.

Using the BlueJeans Cloud Platform

You can log into the BlueJeans Cloud platform, and join the BlueJeans meeting.



Joining the BlueJeans Meeting

To join the BlueJeans meeting:

1. Press  (**Call** soft key) or  to enter the dialing screen.
2. Select **BlueJeans** from the pull-down list of **Call Type** before connection.

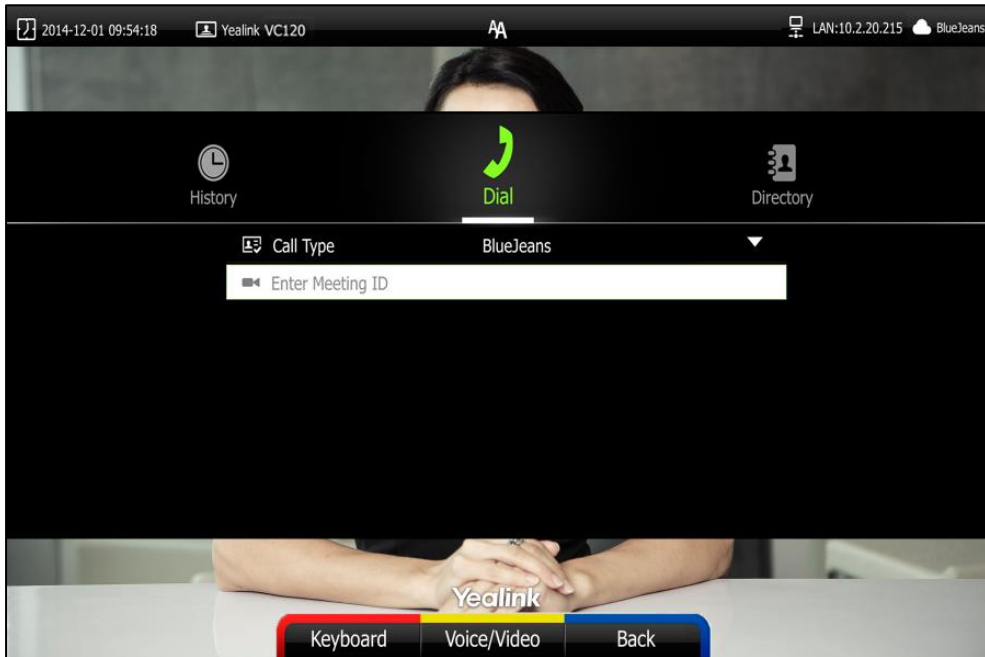
3. Enter meeting ID using the keypad or the on-screen keyboard.



4. Press  (**Voice/Video** soft key) to change call mode.
5. Press  or .
6. Follow the voice prompt to join the BlueJeans meeting.

Note

If you enter nothing or enter wrong information, you can still be sent to the BlueJeans welcome screen.

Using the Pexip Platform



You can register the Pexip account.

When you place a call using the Pexip account, you can:

- Call the device alias to establish a point to point call.
- Call the aliases to join the Virtual Meeting Rooms, Virtual Auditoriums or Virtual Receptions.
- Call between Pexip account and Microsoft Skype for Business/Lync account.



Dialing Pexip Alias

To dial Pexip alias using the remote control:

1. Press  (**Call** soft key) or  to enter the dialing screen.
2. Select the registered alias.

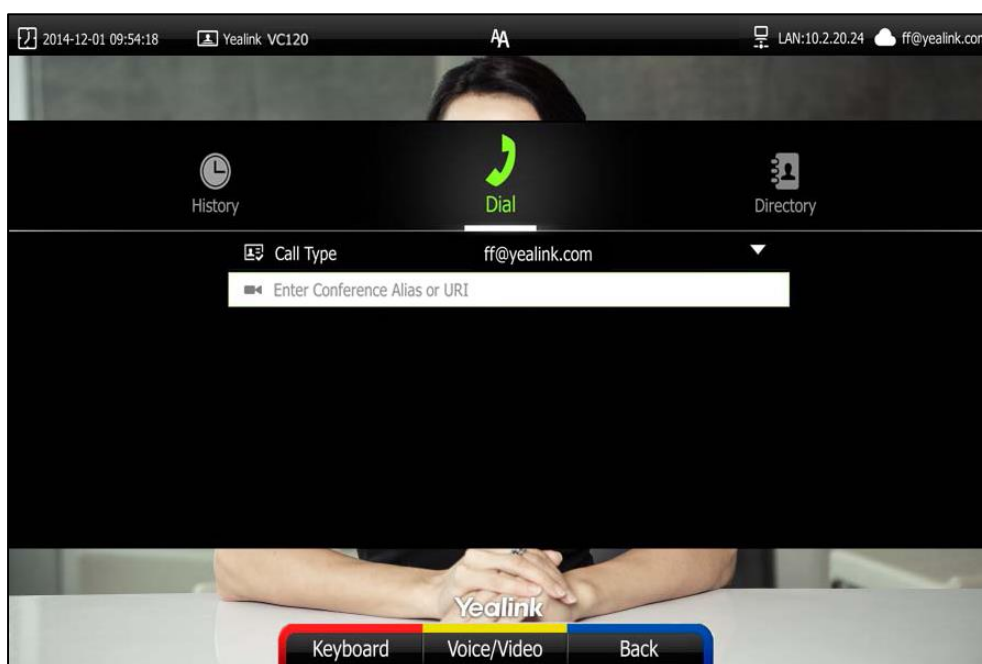

3. Enter the device alias or URI using the keypad or the on-screen keyboard.



4. Press  (**Voice/Video** soft key) to change call mode.
5. Press  or .



Joining the Pexip Meeting

To join the Pexip meeting:

1. Press  (**Call** soft key) or  to enter the dialing screen.
2. Select the registered alias.

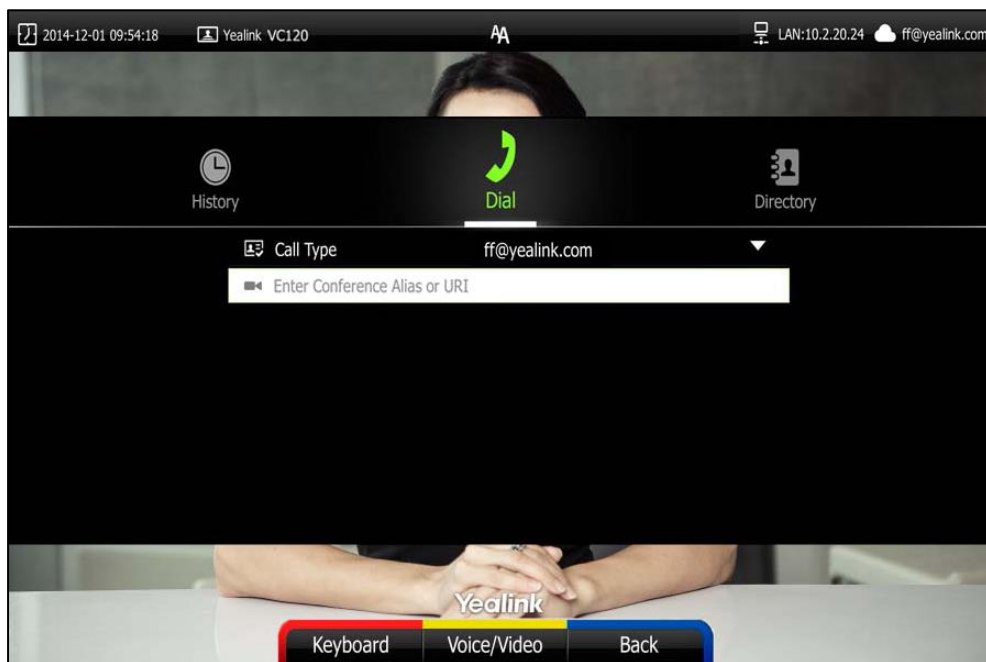
3. Enter the conference alias or URI using the keypad or the on-screen keyboard.



4. Press  (**Voice/Video** soft key) to change call mode.
5. Press  or .
6. Follow the voice prompt to join the Pexip meeting.

Using the Mind Platform

You can log into the Mind platform, and join the Mind meeting.



Joining the Mind Meeting

To join the Mind meeting:

1. Press  (**Call** soft key) or  to enter the dialing screen.
2. Select **Mind** from the pull-down list of **Call Type** before connection.

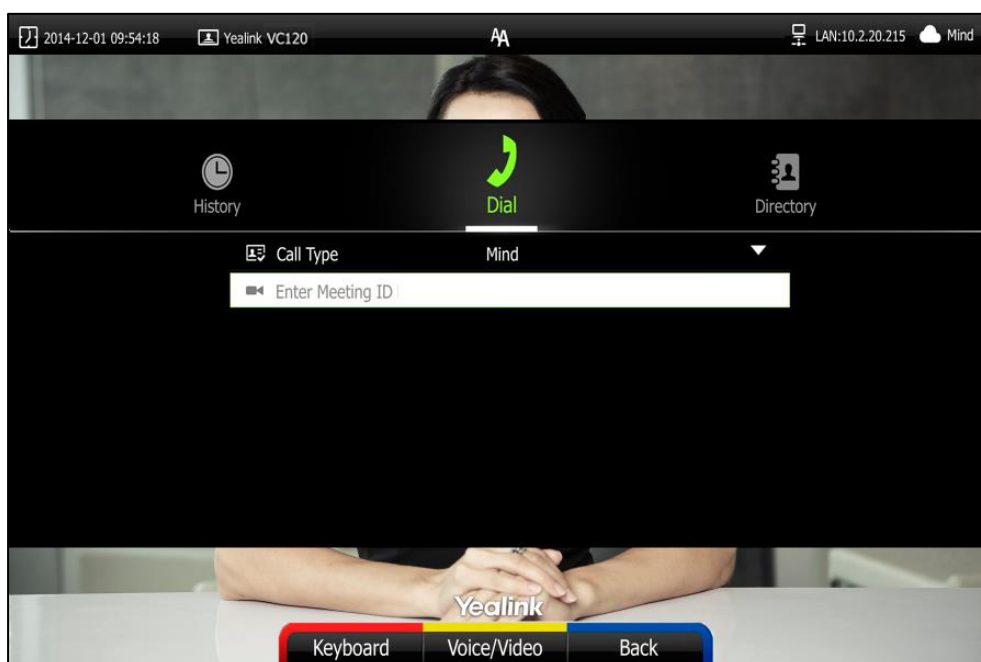
3. Enter meeting ID using the keypad or the on-screen keyboard.



4. Press  (**Voice/Video** soft key) to change call mode.
5. Press  or .
6. Follow the voice prompt to join the Mind meeting.

Using the Custom Platform

When you register a custom account, you can use the corresponding platform feature.

Using VCP41 with the PC or Mobile Device

You connect a PC or mobile device to your VCP41 video conferencing phone, so that the VCP41 can work as the audio input/output device of your PC or mobile device.



Connecting a PC or Mobile Device to the VCP41

You can connect a PC or mobile device to the VCP41 when your VC120 video conferencing system is idle, is placing a call or during a call.

To connect a PC or mobile device to your VCP41:

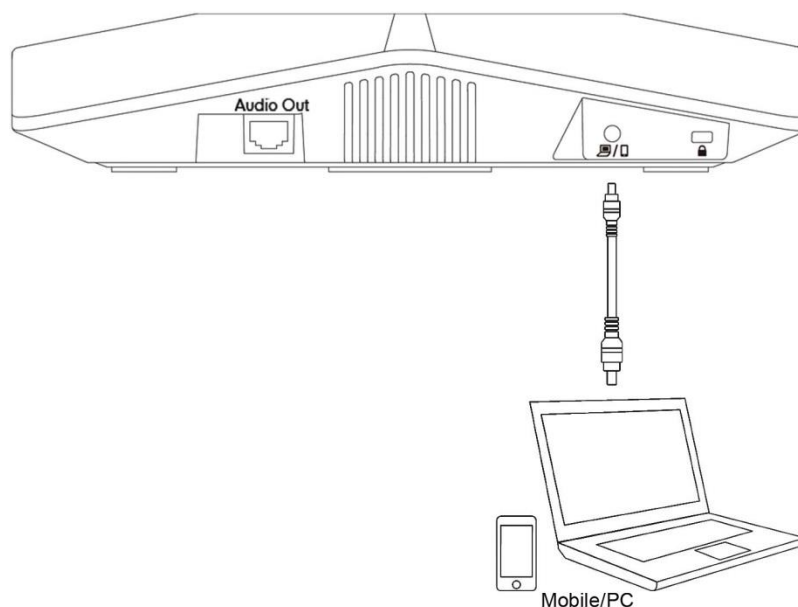
1. Connect one end of the 3.5mm audio cable to the PC/mobile port on the VCP41 phone, and connect the other end to the headset jack on the mobile device or the AUX/MIC jack on the PC.



The  icon will appear on the display device, and the icon  will appear on the video conferencing phone.



As a result, VCP41 will work as the audio input/output device of your PC or mobile device. For example, when the PC or mobile device is playing a video or music, you can listen to the audio on your VCP41. If your PC or mobile device receives an incoming call, you can use VCP41 to listen and speak.

Adjusting the Volume of the PC or Mobile Audio

When your PC or mobile device is during a call, you can adjust the output volume of the PC/mobile device via your VCP41.

To adjust the volume of the PC or mobile device:

1. When your PC or mobile device is during a call, press  on the VCP41 to adjust the volume.

Removing the PC or Mobile Audio

To remove the PC or mobile device, disconnect the 3.5mm audio cable from the VCP41.

Using the VCM30 Video Conferencing Microphone Array

This chapter provides basic operating instructions for the VCM30 video conferencing microphone array. Topics include:

- [Placing the VCM30](#)
- [Muting or Unmuting the VCM30](#)
- [Viewing VCM30 Information](#)

If you require additional information or assistance with your new phone, contact your system administrator.

Placing the VCM30

The VCM30 has a rubber pads on its base to prevent it from sliding. You can place the VCM30 on a stable surface and keep it away from obstacles so that it can effectively pick up sounds.

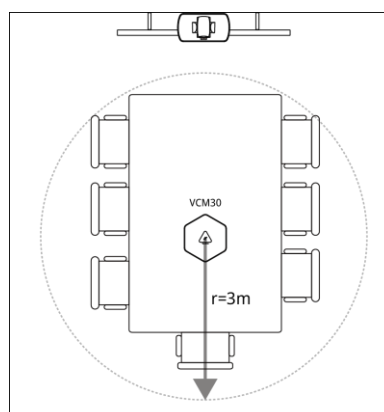



Muting or Unmuting the VCM30



There is a mute button on the top of the VCM30. You can mute or unmute it in the following scenarios:

- If you do not want to have your voice broadcast during a call, you can tap the mute button to mute the VCM30.
- If you want to speak again during a call, you can tap mute button to unmute the VCM30.

To mute the VCM30 during a call:

1. Tap  to mute the call.
The mute indicator LED illuminates solid red. And the  mute icon appears on the local video image.

To unmute the VCM30 during a call:

1. Tap  again to unmute the call.
The mute indicator LED illuminates solid green. And the  mute icon disappears from the local video image.







Viewing VCM30 Information

When the VCM30 is connected to the Audio In port of VC120 codec, you can view VCM30 status via the remote control or web user interface.

Available information of VCM30 includes:

- Status
- Model
- Hardware
- Serial Number

To view the VCM30 information via the remote control:

1. Press  (Menu soft key) to enter main menu.
2. Press  or  to select the **Status** menu.
3. Press  or  to scroll to select the **Wired Micpod**, and then press .

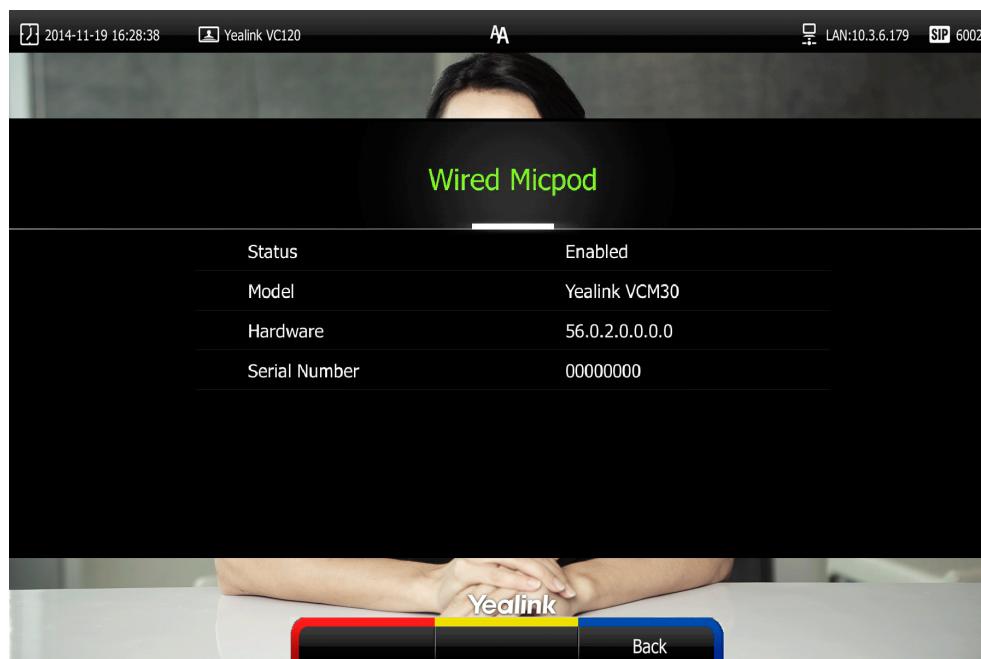

VCM30 information can be viewed via web user interface at the path **Status->Wired Micpod.**

Troubleshooting

This chapter provides general troubleshooting information to help you solve problems you might encounter when using your VC120 system. If you require additional information or assistance with your new phone, contact your system administrator.







Ensure the system has not been physically damaged when experiencing a problem. Check whether the cables are loose and the connections are correct and secure. These are common causes of problems.

System Diagnostics

Diagnostic menus include:

- **Audio Diagnose:** Check whether the audio output device can pick up voice and play audio normally.
- **Camera Diagnose:** Check whether the camera can pan and change focus normally.
- **Ping:** Check whether the network between the local and the remote system is connected.
- **Trace Route:** Display the route (path) and measure transit delays of packets across an Internet Protocol (IP) network.











Audio Diagnose:

1. Press  (**Menu** soft key) to enter main menu.
2. Press  or  to select the **Diagnose** menu.
3. Press  or  to scroll to **Audio Diagnose**, and then press .
4. Speak into the microphone.
5. Check whether the microphone can pick up audio normally.

If the microphone picks up audio and plays back audio normally, it means that the audio works well.

6. Press  to stop audio diagnostics.











Camera Diagnose:

1. Press  (**Menu** soft key) to enter main menu.
2. Press  or  to select the **Diagnose** menu.
3. Press  or  to scroll to **Camera Diagnose**, and then press .
4. Press  or  to adjust the camera position.
5. Press  or  to adjust the focus.

If the camera can move and zoom normally, it means that the camera is working well.











6. Press  (**Back** soft key) to stop camera diagnostics.

Network diagnosis:

1. Press  (**Menu** soft key) to enter main menu.
2. Press  or  to select the **Diagnose** menu.
3. Press  or  to scroll to **Ping**, and then press .
4. Enter IP address (for example, the IP address of the remote system)
5. Press  or  to select **Start**, and then press .
6. Press  (**Back** soft key) to return to Diagnose menu.

It measures the round-trip time from transmission to reception and reports errors and packet loss. The results of the test include a statistical summary of the response packets received, including the minimum, maximum, and the mean round-trip times.

Trace Route:

1. Press  (**Menu** soft key) to enter main menu.
2. Press  or  to select the **Diagnose** menu.
3. Press  or  to scroll to **Trace Route**, and then press .
4. Enter IP address (for example, the IP address of the remote system)
5. Press  or  to select **Start**, and then press .
6. Press  (**Back** soft key) to return to Diagnose menu.

If the test is successful, the VC120 system lists the hops between the system and the IP address you entered. You can check whether congestion happens via the time cost between hops.

General Issues

Why can't the system place a call?

- Check the network is available.
- When making a call using an account, check that the account is registered.
- Ensure the remote system supports the same call protocol as the local system. If you want to place a call using another protocol, refer to [Call Protocol](#) on page 86.

Why can't the system receive calls?

- Check the network is available.
- When receiving a call using an account, check that the account is registered.
- Check that DND (Do Not Disturb) mode is deactivated on your system. Refer to [Do Not Disturb \(DND\)](#) on page 109.



Why doesn't the display device display the time and date correctly?

Check whether you have configured the system to obtain the time and date from the SNTP

server automatically. If the system fails to connect to the SNTP server, contact your system administrator for more information. You can also configure the time and date manually. For more information, refer to [Time & Date](#) on page 60.

How to obtain the IP address of the system?

There are three ways to obtain the IP address of the system:

- The IP address of the system is shown on the top right corner of the display device.
- Press  (Menu soft key) on your remote control and select **Network**.
The display device shows the network information about the system.
- Press  on the video conferencing phone when the phone is idle and select **Network**.
The LCD screen of the phone displays the network information about the system.

Why does the system fail to call the far site?

- Check whether the network of the near site is available.
- Check whether the network of the far site is available.
- Check whether the far site enables the DND feature.
- Check whether the accounts have been registered correctly, and the system uses the appropriate account to call the far site.
- Check whether the local system can ping the IP address of the remote system successfully.
- Ensure that the entered call information is correct.
- Ensure that the called party is powered on.
- Check whether the far site rejects your call.
- Check whether the firewall blocks the inbound traffics from the other site.
- Check whether the far site has already up to maximum call-in limitation.
- If the near site is forced to use encryption, ensure that the far site enables encryption too.
- Ensure that the far site supports the same call protocol as the near site.

Why does the system fail to call the far site via IP address?

- Ensure that the network is connected correctly.
- Ping the IP address of the far site. Contact your system administrator if it fails.

Camera Issues

How to adjust room lighting?

You can alter the environmental lighting and background colors of your environment to obtain the best video quality. If light levels are too low you may consider adding artificial lighting.

Reflected light from pale walls often produces excellent results.

Avoid the following situations:

- Direct sunlight on the display device, the background, or the camera lens which creates harsh contrasts.
- Colored lighting.

Why can't I adjust the camera angle and focus?

- You can adjust the camera when the system is idle or during a call. The camera cannot be adjusted when the system is in the menu screen.
- Ensure that the batteries in the remote control are in good working condition, and installed correctly.
- Aim the remote control at the sensor when you perform a task.
- Ensure that no objects are obstructing the sensor on the front of the camera.
- Ensure that the LED on the front of the camera flashes green when you use the remote control to perform a task.
- Ensure that what you are controlling is the local camera.
- Reboot the system.
- If the above suggestions cannot solve your problem, perhaps the remote control is broken. You can contact your system administrator for help.

Why is the video quality bad?

- Ensure that the display device has suitable resolution.
- Check whether the packet has been lost. For more information on packet loss, refer to [Call Statistics](#) on page 113.
- Contact your administrator to adjust the camera brightness and white balance.

Display Issues

Why is there no video on the display device?

- Ensure that the display device is turned on.
- Ensure that the display device is properly connected to the VC120 codec.
- Ensure that the VC120 codec is turned on.
- Ensure that you have selected the correct video input source.

Why can't the display device share a presentation?

- Ensure that the PC is properly connected to the VC120 codec.
- Ensure that the VC120 codec is turned on.



- Contact your administrator for help.

Video & Audio Issues

Why can't I hear the audio during a call?

- Ensure that the system has selected an available audio output device.
- If you select **VCS Phone** as the audio output device, ensure that the video conferencing phone is connected to the VC120 codec, and LED indicators on the phone illuminate solid green.
- Ensure the proper volume level on the system.
- Ensure that the microphone on the remote system is not muted.

Why can't I hear a ring tone when receiving a call?

- Ensure that the system has selected an available audio output device.
- If you select **VCS Phone** as the audio output device, ensure that the video conferencing phone is connected to the VC120 codec, and LED indicators on the phone illuminate solid green.
- Ensure that the ring volume is not set to 0. If it is, the  icon will appear on the status bar of display device, and the  icon will appear on the LCD screen of the video conferencing phone.
- Adjust the ring volume when the system is idle via the remote control or video conferencing phone. For more information, refer to [Volume Settings](#) on page 64.
- Ensure that the microphone of the remote system is not muted.

Why can't I view the menu on the display device?

- Check whether the Display1 port of VC120 codec is connected to the HDMI port on the display device.

Why can't I hear the other site clearly during a call?

- Ensure that the speaker volume of the far site is not set too low.
- Muffled audio reception from the far side may be caused by highly reverberant rooms. Speak in close proximity to the phone.
- Adjust the priority order for your audio codec if you have chosen a low-bandwidth audio codec to be first.
- For best results, ensure that the caller is using a Yealink video conferencing system. Audio quality from your video conferencing system will vary when calling a non-Yealink system.
- Dust and debris may cause audio quality. Do not use any kind of liquid or aerosol cleaner on the phone. A soft, slightly damp cloth should be sufficient to clean the top surface of

the phone if necessary.





Why is the voice quality poor?

Users may receive poor voice quality during a call, such as intermittent voice, low volume, echo or other noise. It is difficult to diagnosis the root causes of the voice anomalies. The possible reasons are:

- Users sit too far from or near to the microphone.
- The audio pickup device is moved frequently.
- Intermittent voice is probably caused by voice packet loss or jitter. Voice packet loss may occur due to network congestion. Jitter may occur due to information reorganization of the transmission or receiving equipment, such as, delay processing, retransmission mechanism or buffer overflow.
- Noise devices, such as computers or fans, may make it difficult to hear each other's voices clearly.
- Wires may also cause this problem. Replace the old with the new cables, and then reconnect to check whether the new cables provide better connectivity.

System Maintenance

How to reboot the phone?

1. Press  (**Menu** soft key) to enter main menu.
2. Press ◀ or ▶ to scroll to the **Advanced** menu.
3. Enter admin password (default password: 0000) in the **Admin Password** field.
4. Press  or press  (**Enter** soft key).
5. Press ▲ or ▼ to scroll to **Reboot & Reset**, and then press .
6. Press ▲ or ▼ to scroll to **Reboot**, and then press .

The display device prompts “Reboot the system?”.

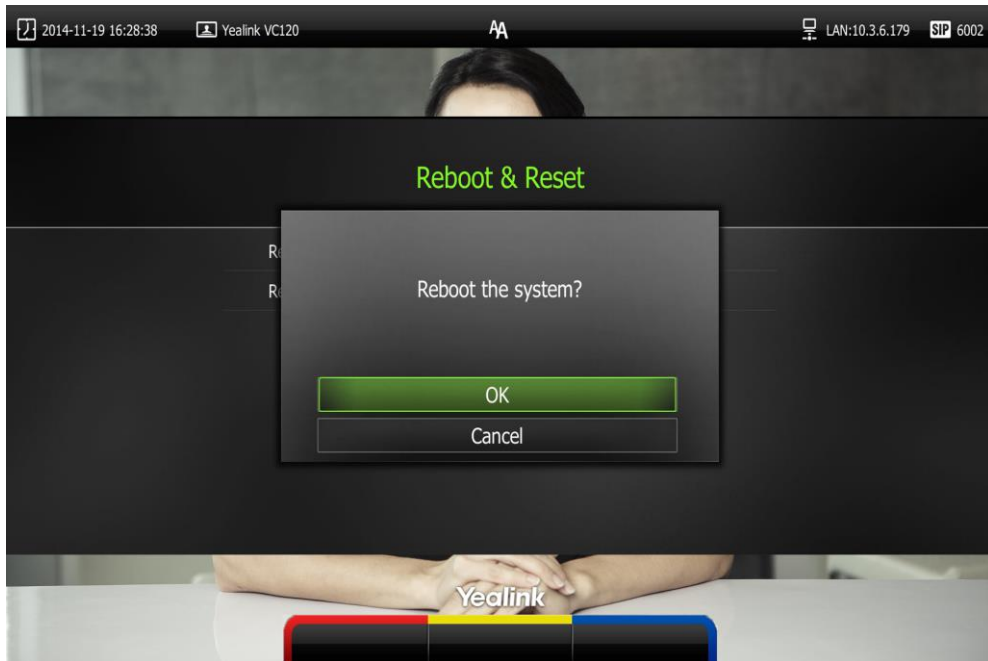

7. Select **OK**, and then press **OK**.

You can reboot the system via web user interface at the path **Setting->Upgrade->Reboot**.

How to export PCAP trace?

We may need you to provide a PCAP trace to help analyze your problem. Exporting PCAP trace is configurable via web user interface and remote control.

To export a PCAP trace via web user interface:

1. Click on **Settings->Configuration**.
2. Click **Start** to begin capturing signal traffic.

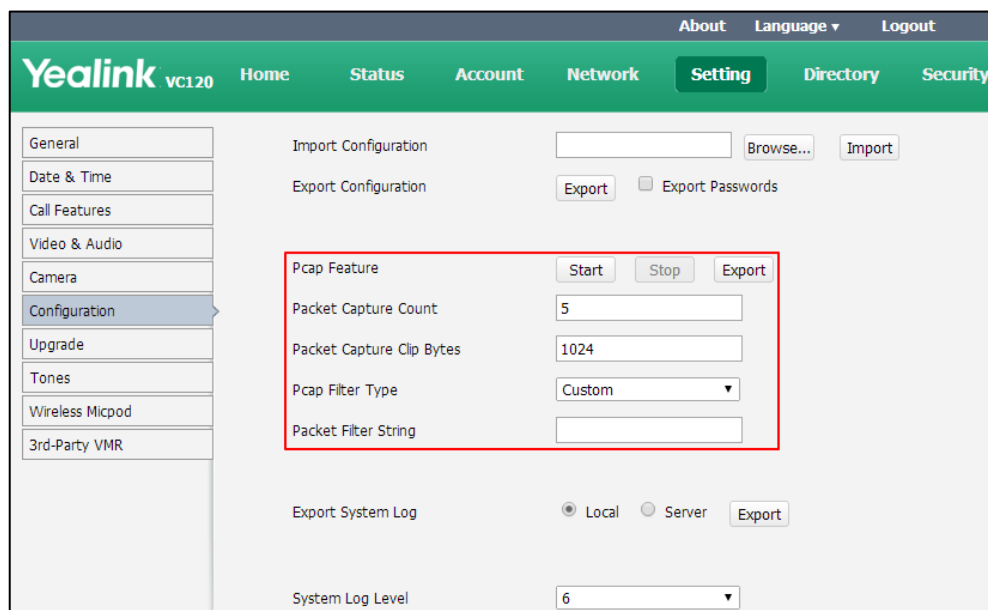



3. Recreate the error to be documented in the trace.
4. Click **Stop** to stop the capture.
5. Click **Export** to open the file download window, and then save the file to your local system.

You can also configure the count, bytes and filter type of the packet before exporting PCAP trace. For more information, contact your system administrator.

To export a PCAP trace via the remote control:

Before capturing packets, you need to insert a USB flash drive to the USB port on the VC120 Codec to store packets. Make sure the USB feature is enabled.

1. Long press  when the system is idle or during a call.
The display device prompts "Onekey-capture is running, press the Backspace key for 2s to turn off it?".
2. Long press  for 2 seconds to stop capturing packets.
The packets are saved in the yealink.debug folder on your USB flash driver.

How to export system log?

We may need you to provide your phone configurations to help analyze your problems. You can export the system log to a PC or designated log server.

To export the system log to a PC via web user interface:

1. Click on **Settings->Configuration**.
2. Mark the **Local** radio box in the **Export System Log** field.
3. Select **6** from the pull-down list of **System Log Level**.

The default system log level is 6.

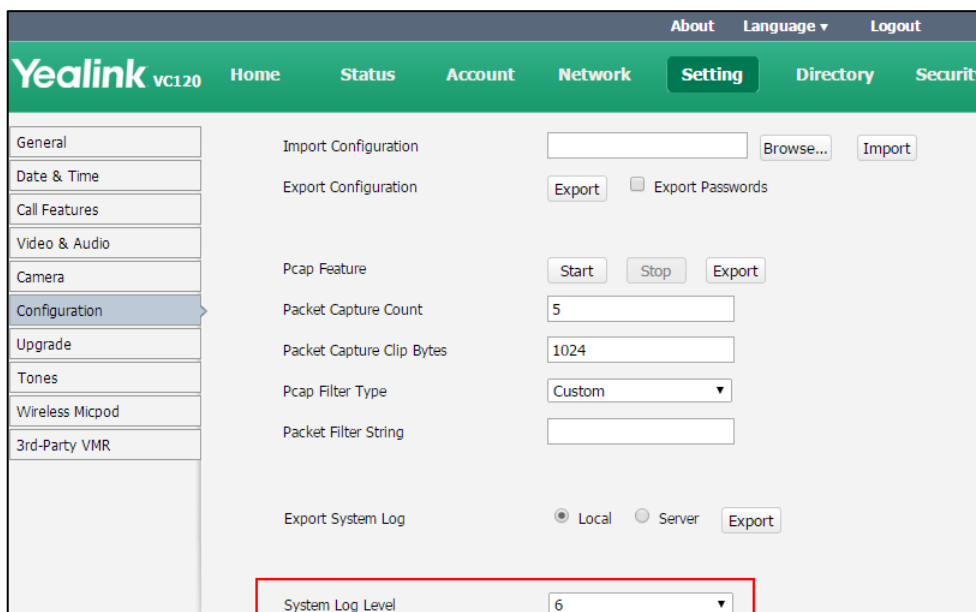

4. Click **Confirm** to accept the change.
The web user interface prompts "Operating...Please wait...".

Export the system log referring to the following steps.

5. Recreate the error to be documented in the trace.
6. Click **Export** to save the file to your local system.

How to export/import the system configurations?

We may need you to provide your system configurations to help analyze problems. In some instance, you may need to import configurations to your system.

To export the system configurations via web user interface:

1. Click on **Setting**->**Configuration**.
2. Check or uncheck the **Export Passwords** checkbox according to actual demand.
3. Click **Export**.

If you check the **Export Passwords** checkbox, the web user interface is shown as below:

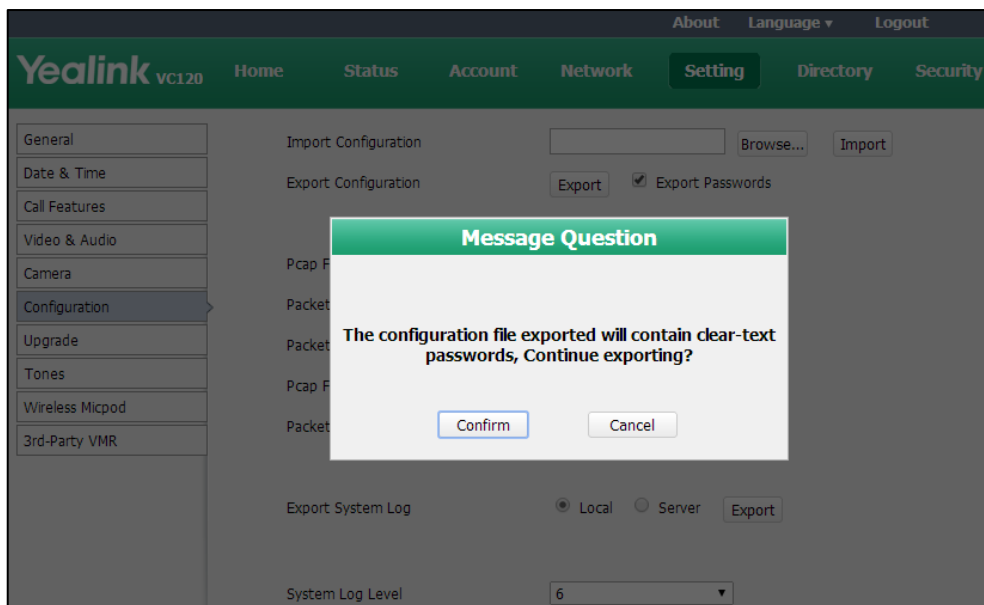

4. Click **Confirm** to export the configurations.

To import the system configurations via web user interface:

1. Click on **Setting**->**Configuration**.

2. Click **Browse** to locate a configuration file from your local system.

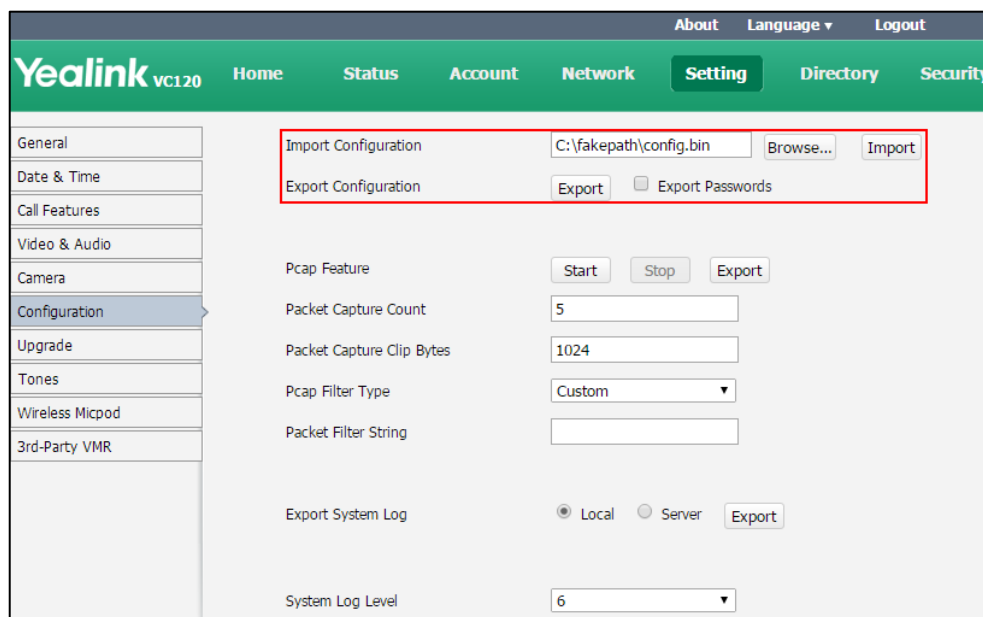

3. Click **Import** to import the configuration file.

Note

The file format of configuration file must be *.bin.

How to upgrade firmware?

To upgrade firmware via web user interface:

1. Click on **Setting->Upgrade**.
2. Click **Browse** to locate the firmware from your local system.

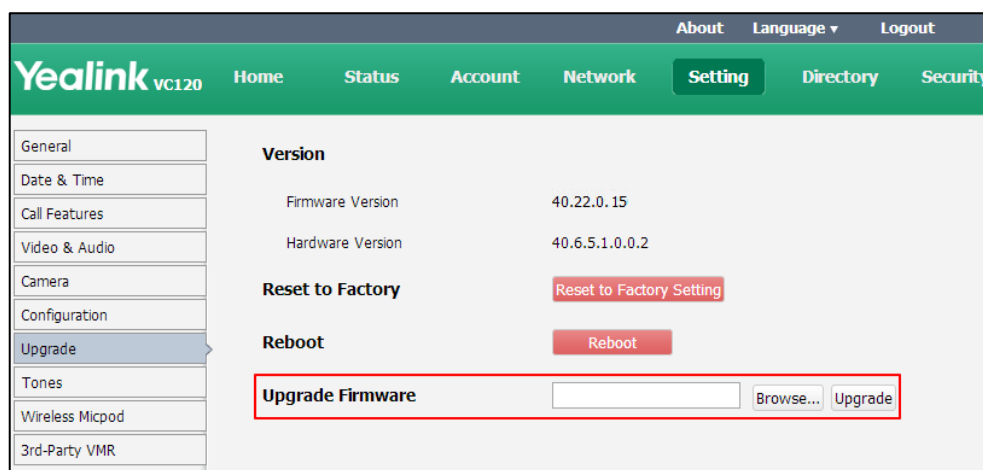

3. Click **Upgrade** to upgrade the firmware.

The browser pops up the dialog box "Firmware of the video conference system will be updated. It will take 5 minutes to complete. Please don't power off!".

4. Click **Confirm** to confirm upgrading.

The web user interface is shown as below:

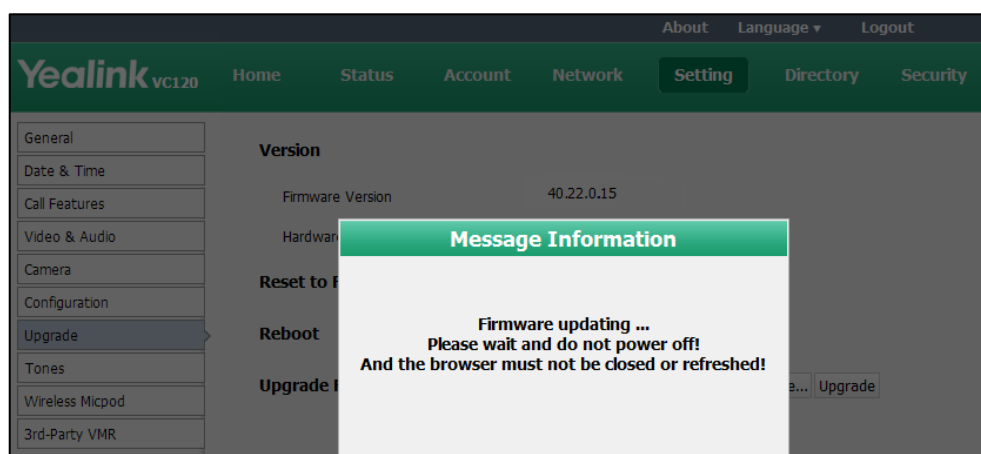

How to upgrade VCC20 Camera firmware?

Camera firmware is included in the system firmware. The VCC20 camera will upgrade automatically in one of the following situations:

- The VCC20 camera has been connected to the VC120 Codec. When you upgrade the VC120 video conferencing system, the VCC20 camera will upgrade automatically.
- After you upgrade the VC120 video conferencing system, and then you connect the VCC20 camera to the VC120 Codec with the supplied DVI cable. The VCC20 will detect the new firmware, and upgrade automatically.

When the VCC20 is updating, the display device prompts “The camera is updating, do not plug out the camera, please waiting...”

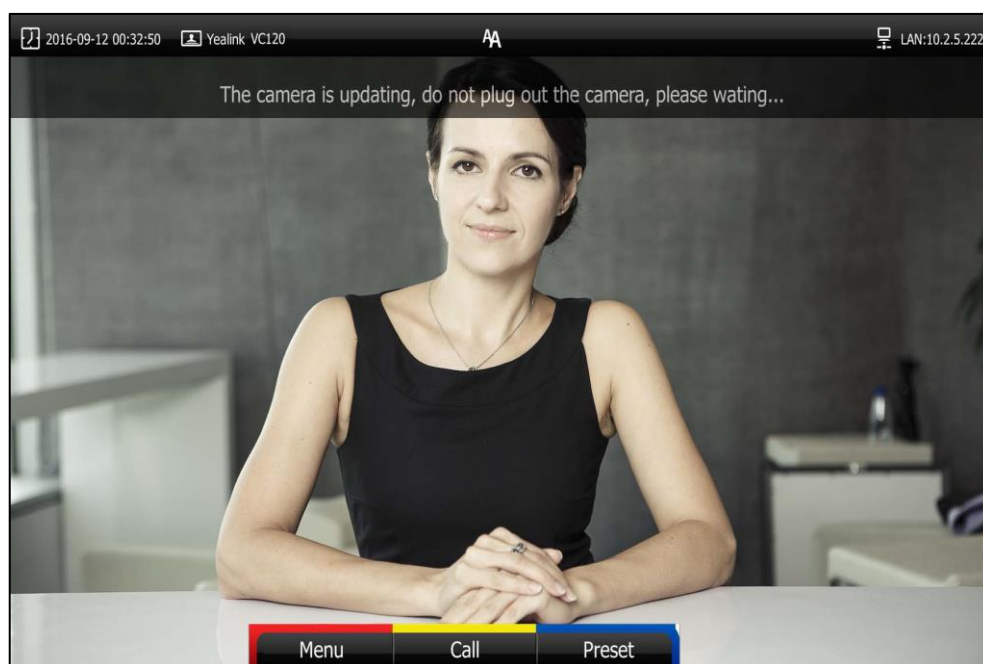





Note

If you connect two VCC20 cameras to the VC120 Codec using the VC Dual-camera Box VCB20 (You should purchase it separately if necessary), the firmware of Camera 1 will be upgraded automatically by default. Only when you change video input resource to Camera 2, will the Camera 2 be upgraded.

How to reset the system?

Reset the system to factory configurations after you have tried all appropriate troubleshooting suggestions but have still not solved the problem. You need to note that all customized settings will be overwritten after reset. You can reset the system via the remote control or web user interface.

To reset the system via the remote control:

1. Press  (**Menu** soft key) to enter main menu.
2. Press ◀ or ▶ to scroll to the **Advanced** menu.
3. Enter admin password (default password: 0000) in the **Admin Password** field.
4. Press  or Press  (**Enter** soft key).
5. Press ▲ or ▼ to scroll to **Reboot & Reset**, and then press .
6. Press ▲ or ▼ to scroll to **Reset**, and then press .

The display device prompts "Reset to Factory?".

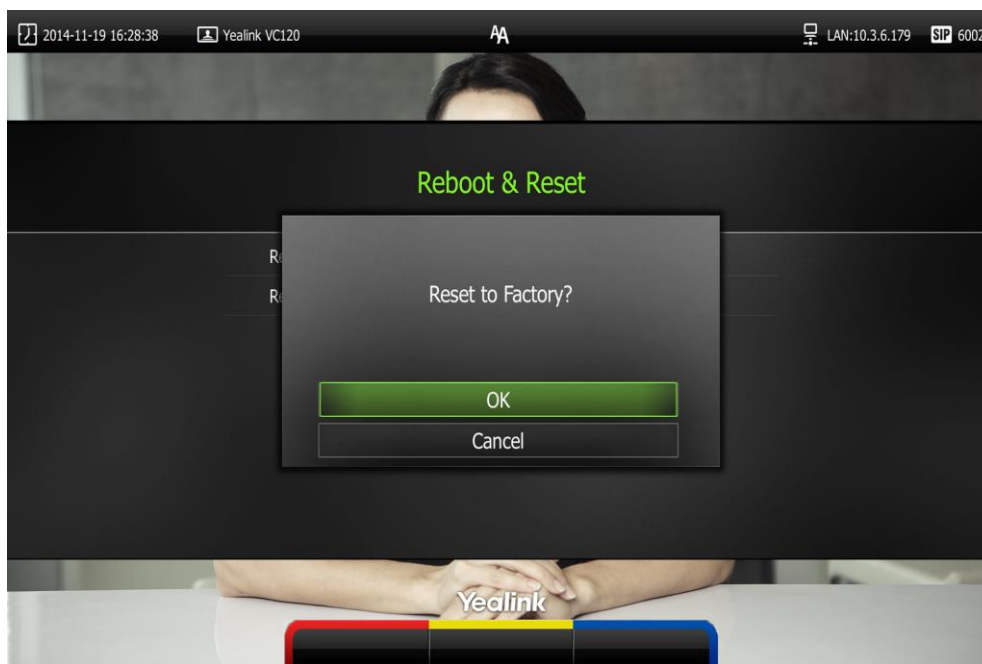

7. Select **OK**, and then press **OK**.

The system reboots automatically, the LCD screen of the video conferencing phone prompts "Rebooting Please wait...". The phone will be reset to factory successfully after startup.

Note

Reset of the system may take a few minutes. Do not power off until the phone starts up successfully.

Resetting the system is configurable via web user interface at the path

Setting->Upgrade->Reset to Factory.

Regulatory Notices

Service Agreements

Contact your Yealink Authorized Reseller for information about service agreements applicable to your product.

Limitations of Liability

TO THE FULL EXTENT ALLOWED BY LAW, YEALINK EXCLUDES FOR ITSELF AND ITS SUPPLIERS ANY LIABILITY, WHETHER BASED IN CONTRACT OR TORT (INCLUDING NEGLIGENCE), FOR INCIDENTAL, CONSEQUENTIAL, INDIRECT, SPECIAL, OR PUNITIVE DAMAGES OF ANY KIND, OR FOR LOSS OF REVENUE OR PROFITS, LOSS OF BUSINESS, LOSS OF INFORMATION OR DATA, OR OTHER FINANCIAL LOSS ARISING OUT OF OR IN CONNECTION WITH THE SALE, INSTALLATION, MAINTENANCE, USE, PERFORMANCE, FAILURE, OR INTERRUPTION OF ITS PRODUCTS, EVEN IF YEALINK OR ITS AUTHORIZED RESELLER HAS BEEN ADVISED OF THE POSSIBILITY OF SUCH DAMAGES, AND LIMITS ITS LIABILITY TO REPAIR, REPLACEMENT, OR REFUND OF THE PURCHASE PRICE PAID, AT YEALINK'S OPTION. THIS DISCLAIMER OF LIABILITY FOR DAMAGES WILL NOT BE AFFECTED IF ANY REMEDY PROVIDED HEREIN SHALL FAIL OF ITS ESSENTIAL PURPOSE.

Safety Instructions

Save these instructions. Read these safety instructions before use!

The following basic safety precautions should always be followed to reduce risk of fire, electrical shock, and other personal injury.



General Requirements

- Before you install and use the device, read the safety instructions carefully and monitor the situation during operation.
- During the process of storage, transportation, and operation, please always keep the device dry and clean.
- During the process of storage, transportation, and operation, please avoid collision and an impact to the device.
- Please do not attempt to dismantle the device by yourself. In case of any discrepancy, please contact the appointed maintenance center for repair.
- Without prior written consent, no organization or individual is permitted to make any change to the structure or the safety design of the device. Yealink is under no circumstance liable to consequences or legal issues caused by such changes.

- Please refer to the relevant laws and statutes while using the device. The legal rights of others should be respected as well.



Environmental Requirements

- Place the device in a well-ventilated place. Do not expose the device under direct sunlight.
- Keep the device dry and free of dust.
- Place the device on a stable and level platform.
- Please do not place any heavy objects on the device in case of damage and deformation caused by the heavy load.
- Keep at least 10 cm between the device and the closest object for heat dissipation.
- Do not place the device on or near any inflammable or fire-vulnerable object, such as rubber-made materials.
- Keep the device away from any heat source or bare fire, such as a candle or an electric heater.
- Keep the device away from any household appliance with a strong magnetic field or electromagnetic field, such as a microwave oven or a refrigerator.



Operating Requirements

- Do not let a child operate the device without guidance.
- Do not let a child play with the device or any accessory in case of accidental swallowing.
- Please only use accessories provided or authorized by the manufacturer.
- The power supply of the device shall meet the requirements of the input voltage of the device. Please only use the surge protection power socket provided.
- Before plugging or unplugging any cable, ensure that your hands are completely dry.
- Do not spill liquid of any kind on the product or use the equipment near water, for example, near a bathtub, washbowl, kitchen sink, wet basement or near a swimming pool.
- Do not tread on, pull, or over-bend any cable in case of malfunction of the device.
- During a thunderstorm, stop using the device and disconnect it from the power supply. Unplug the power plug and the Asymmetric Digital Subscriber Line (ADSL) twisted pair (the radio frequency cable) to avoid lightning strike.
- If the device is left unused for a rather long time, disconnect it from the power supply and unplug the power plug.
- When smoke or an abnormal noise or smell is emitted from the device, disconnect the device from the power supply, and unplug the power plug immediately. Contact the specified maintenance center for repair.
- Do not insert any object into equipment slots that is not part of the product or auxiliary product.
- Before connecting a cable, connect the grounding cable of the device first. Do not disconnect the grounding cable until you disconnect all other cables.



Cleaning Requirements

- Before cleaning the device, stop using it and disconnect it from the power supply.
- Use a piece of soft, dry and anti-static cloth to clean the device.
- Keep the power plug clean and dry. Using a dirty or wet power plug may lead to electric shock or other perils.

Restriction of Hazardous Substances

Restriction of Hazardous Substances (RoHS) is a Chinese government regulation which aims to restrict certain dangerous substances commonly used in electronic and electronic equipment.

The following table lists the names and content of the toxic and hazardous substances or elements probably contained in the products:

Parts Name	Toxic or Hazardous Substance and Elements					
	Lead (Pb)	Mercury (Hg)	Cadmium (Cd)	Hexavalent Chromium (Cr ⁺⁶)	Polybrominated Biphenyls (PBB)	Polybrominated Diphenyl Ethers (PBDE)
Plastic and Polymeric Parts	O	O	O	O	O	O
Metal Parts	X	O	O	O	O	O
PCBA	X	O	O	O	O	O
Cables and Cable Assemblies	O	O	O	O	O	O
LCD Screen	O	O	O	O	O	O
Batteries	O	O	O	O	O	O
Packing Material	O	O	O	O	O	O

O: Indicates that toxic substances contained in all homogeneous materials in this product are below the limit requirement in GB/T26572-2011 standard.

X: Indicates that toxic substances contained in all homogeneous materials in this product are above the limit requirement in GB/T26572-2011 standard.

This table lists the toxic and hazardous substances contained in the machine. Based on the material type, the data is provided by the supplier and has already been validated by Yealink company.

Some harmful substances contained in the material cannot be replaced according to the current technology. We constantly strive to improve our products.

Appendix A - Time Zones

Time Zone	Time Zone Name
-11:00	Samoa
-10:00	United States-Hawaii-Aleutian
-10:00	United States-Alaska-Aleutian
-09:30	French Polynesia
-09:00	United States-Alaska Time
-08:00	Canada(Vancouver, Whitehorse)
-08:00	Mexico(Tijuana, Mexicali)
-08:00	United States-Pacific Time
-07:00	Canada(Edmonton, Calgary)
-07:00	Mexico(Mazatlan, Chihuahua)
-07:00	United States-Mountain Time
-07:00	United States-MST no DST
-06:00	Canada-Manitoba(Winnipeg)
-06:00	Chile(Easter Islands)
-06:00	Mexico(Mexico City, Acapulco)
-06:00	United States-Central Time
-05:00	Bahamas(Nassau)
-05:00	Canada(Montreal, Ottawa, Quebec)
-05:00	Cuba(Havana)
-05:00	United States-Eastern Time
-04:30	Venezuela(Caracas)
-04:00	Canada(Halifax, Saint John)
-04:00	Chile(Santiago)
-04:00	Paraguay(Asuncion)
-04:00	United Kingdom-Bermuda(Bermuda)
-04:00	United Kingdom(Falkland Islands)
-04:00	Trinidad&Tobago
-03:30	Canada-New Foundland(St.Johns)
-03:00	Denmark-Greenland(Nuuk)
-03:00	Argentina(Buenos Aires)
-03:00	Brazil(no DST)
-03:00	Brazil(DST)
-02:30	Newfoundland and Labrador
-02:00	Brazil(no DST)
-01:00	Portugal(Azores)
0	GMT
0	Greenland

Time Zone	Time Zone Name
0	Denmark-Faroe Islands(Torshavn)
0	Ireland(Dublin)
0	Portugal(Lisboa, Porto, Funchal)
0	Spain-Canary Islands(Las Palmas)
0	United Kingdom(London)
0	Morocco
+01:00	Albania(Tirane)
+01:00	Austria(Vienna)
+01:00	Belgium(Brussels)
+01:00	Caicos
+01:00	Chad
+01:00	Spain(Madrid)
+01:00	Croatia(Zagreb)
+01:00	Czech Republic(Prague)
+01:00	Denmark(Kopenhagen)
+01:00	France(Paris)
+01:00	Germany(Berlin)
+01:00	Hungary(Budapest)
+01:00	Italy(Rome)
+01:00	Luxembourg(Luxembourg)
+01:00	Macedonia(Skopje)
+01:00	Netherlands(Amsterdam)
+01:00	Namibia(Windhoek)
+01:00	Poland (Warsaw)
+02:00	Estonia(Tallin)
+02:00	Finland(Helsinki)
+02:00	Gaza Strip(Gaza)
+02:00	Greece(Athens)
+02:00	Israel(Tel Aviv)
+02:00	Jordan(Amman)
+02:00	Latvia(Riga)
+02:00	Lebanon(Beirut)
+02:00	Moldova(Kishinev)
+02:00	Russia(Kaliningrad)
+02:00	Romania(Bucharest)
+02:00	Syria(Damascus)
+02:00	Turkey(Ankara)
+02:00	Ukraine(Kyiv, Odessa)
+03:00	East Africa Time
+03:00	Iraq(Baghdad)
+03:00	Russia(Moscow)
+03:30	Iran(Teheran)

Time Zone	Time Zone Name
+04:00	Armenia(Yerevan)
+04:00	Azerbaijan(Baku)
+04:00	Georgia(Tbilisi)
+04:00	Kazakhstan(Aktau)
+04:00	Russia(Samara)
+04:30	Afghanistan(Kabul)
+05:00	Kazakhstan(Aqtobe)
+05:00	Kyrgyzstan(Bishkek)
+05:00	Pakistan(Islamabad)
+05:00	Russia(Chelyabinsk)
+05:30	India(Calcutta)
+05:45	Nepal(Katmandu)
+06:00	Kazakhstan(Astana, Almaty)
+06:00	Russia(Novosibirsk, Omsk)
+06:30	Myanmar(Naypyitaw)
+07:00	Russia(Krasnoyarsk)
+07:00	Thailand(Bangkok)
+08:00	China(Beijing)
+08:00	Singapore(Singapore)
+08:00	Australia(Perth)
+08:00	Russia(Irkutsk, Ulan-Ude)
+08:45	Eucla
+09:00	Korea(Seoul)
+09:00	Japan(Tokyo)
+09:00	Russia(Yakutsk, Chita)
+09:30	Australia(Adelaide)
+09:30	Australia(Darwin)
+10:00	Australia(Sydney, Melbourne, Canberra)
+10:00	Australia(Brisbane)
+10:00	Australia(Hobart)
+10:00	Russia(Vladivostok)
+10:30	Australia(Lord Howe Islands)
+11:00	New Caledonia(Noumea)
+11:00	Russia(Srednekolymsk Time)
+11:30	Norfolk Island
+12:00	New Zealand(Wellington, Auckland)
+12:00	Russia(Kamchatka Time)
+12:45	New Zealand(Chatham Islands)
+13:00	Tonga(Nukualofa)
+13:30	Chatham Islands
+14:00	Kiribati

Index

8

8-Way Conference License [130](#)

A

About This Guide [v](#)
Account Polling [93](#)
Adding a Local Contact from the Call History List [85](#)
Adding Contacts [72](#)
Adjusting the Camera [120](#)
Answering or Rejecting Calls [107](#)
Appendix A - Time Zones [169](#)
Audio Input Device [90](#)
Audio Output Device [89](#)
Audio Settings [89](#)
Auto Answer [108](#)
Automatic Sleep Time [55](#)

B

Backlight [56](#)
Bandwidth Settings [87](#)
Blacklist [69](#)

C

Call History Management [80](#)
Call Management [112](#)
Call Mute [112](#)
Call Protocol [86](#)
Call Statistics [112](#)
Camera Issues [153](#)
Chairman-Mode Conference [99](#)
Changing the Video Layout [116](#)
Changing Video Input Source [123](#)
Configuring Camera Presets [121](#)
Controlling the Camera [120](#)
Customizing VC120 Video conferencing system [55](#)

D

Declaration of Conformity [vi](#)
Deleting an Entry from the Call History List [83](#)
Deleting Contacts [75](#)
Directory [69](#)
Display Issues [154](#)
Dialing Pexip Alias [140](#)
Dialing StarLeaf Cloud Numbers [137](#)
Dialing Yealink Cloud Numbers [135](#)
Documentations [34](#)
Do Not Disturb (DND) [109](#)
Dual Screen [118](#)

E

Editing Contacts [74](#)
Ending Calls [111](#)
System Component Instructions [17](#)
System Diagnostics [151](#)
System Installation [37](#)
System Maintenance [156](#)
System Status [52](#)
Entering Data and Editing Fields [50](#)

F

Far-end Camera Control [89](#)

G

General Issues [152](#)
General Settings [55](#)
Getting Started [34](#)

H

Hiding Icons in a Call [70](#)

I

- Icon Instructions [29](#)
- Idle Screen Display [47](#)
- Importing/Exporting Contact Lists [78](#)
- Installing Batteries for the Remote Control [41](#)
- Installing the Camera [39](#)
- Installing the VC120 Video conferencing system [38](#)
- In This Guide [v](#)

J

- Joining the BlueJeans Meeting [139](#)
- Joining the Mind Meeting [142](#)
- Joining the Pexip Meeting [141](#)
- Joining the StarLeaf Meeting [137](#)
- Joining the Zoom Meeting [138](#)

K

- Keyboard Input Method [50](#)
- Key Tone [62](#)

L

- Language [58](#)
- LED Instructions [32](#)
- Limitation of Liability [165](#)

M

- Meeting Blacklist [69](#)
- Meeting Password [66](#)
- Meeting Whitelist [68](#)
- Muting or Unmuting the VCM30 [147](#)

N

- Navigating Menus on the Display Device [49](#)

P

- Packaging Contents [13](#)
- Placing a Call from the Call History List [82](#)
- Placing a Call Using the Remote Control [97](#)
- Placing a Call Using the Video Conferencing Phone [97](#)

- Placing a Call via web user Interface [98](#)
- Placing Calls [93](#)
- Placing Multiple Calls [98](#)
- Placing the VCM30 [147](#)
- Powering the System On or Off [42](#)
- Presentation [114](#)

O

- Overview [13](#)

R

- Remote Control via the Web Interface [35](#)
- Registration [42](#)
- Regulatory Notices [165](#)
- Remote Control [34](#)
- Remote Control Battery Safety Information [41](#)
- Restriction of Hazardous Substances [167](#)

S

- Safety Instructions [165](#)
- Screenshot [128](#)
- Searching for Contacts [75](#)
- Search Source List in Dialing [76](#)
- Service Agreements [165](#)
- Setup Wizard [42](#)
- Site Name [57](#)
- Summary of Changes [v](#)

T

- Table of Contents [ix](#)
- Time & Date [60](#)
- Troubleshooting [151](#)

U

- USB Configuration [70](#)
- User Interfaces [33](#)
- Using the BlueJeans Cloud Platform [139](#)
- Using the Custom Platform [143](#)
- Using the Mind Platform [142](#)
- Using the Pexip Platform [140](#)
- Using the StarLeaf Cloud Platform [136](#)

Using the VCM30 Video Conferencing
Microphone Array [135](#)
Using VC120 Video Conferencing System [93](#)
Using VCP41with the PC or Mobile Device [135](#)
Using the Yealink Cloud Platform [135](#)
Using the Zoom Cloud Platform [136](#)

V

VC120 Codec [17](#)
VCC18/VCC20 HD Camera [19](#)
VCM30 Video Conferencing Microphone Array
[24](#)
VCR10 Remote Control [26](#)
Video Conferencing Phone [19](#)
Video & Audio Issues [155](#)
Video Recording [124](#)
Viewing Call History [81](#)
Viewing VCM30 Information [148](#)
Volume Settings [64](#)

W

Website Snapshot [63](#)
Web User Interface [34](#)
WEEE Warning [vii](#)